



Flight Light Inc.
2708 47th Ave.
Sacramento, California, U.S.A.
95822-3806

atg airports (formerly ALSTOM)
**ZA183, ZA188 High Intensity
Runway Edge, Threshold and
End Inset Light**

PH (916) 394-2800 FX (916) 394-2809
TF (800) 806-3548 EM info@flightlight.com

**FAA Compliant: L-850C & D,
NATO Stanag 3316, ICAO Annex 14**

Compliance and Applications

FAA Compliant: L-850C & D
(AC 150/5345-46B)
NATO Stanag 3316
ICAO Annex 14

Category I, II and III all weather
operation airfield lighting systems.

Suitable for use as high intensity inset
runway edge light (L850C) and runway
threshold light (L850D).

Why Our ZA183 is Better

- ✓ Lightweight and robust aluminum alloy construction.
- ✓ Prism removal and replacement achieved without need for adhesives or sealants.
- ✓ Pre-focused optics simplify maintenance.
- ✓ Pressure test plug ensures moisture-proof light cavity.
- ✓ Installation and maintenance manual AVD 104.
- ✓ 8" sealed optical cartridge fits 12" adapter ring and is held with two stainless steel bolts for ease of maintenance.

Specifications

- Low profile: 0.47" (12mm) projection.
- Long life lamps: 1,500 hours at full intensity. Over 3,500 hours in normal use.
- 6.6A from 100W, or 200W isolating transformer. Uses 2@105W lamps.
- Corrosion resistant anodized finish. Stainless steel fasteners.
- Fixture net weight 31 lb. (14kg). Gross weight 33 lb. (15kg). Carton size 12.7 in. x 12.7 in. x 5 in. (323mm x 323mm x 127mm).



ZA183 Series bi/unidirectional high intensity inset light.

APPLICATION VARIATIONS

FAA#	Application	Config.	Lamp(s)	Color	Code
L-850C	Runway Edge	Bidirectional	2	White/White	80-ZA183-WW
L-850C	Runway Edge	Bidirectional	2	White/Yellow	80-ZA183-WY
L-850C	Runway Edge	Bidirectional	2	Yellow/Green	80-ZA183-YG
			2	Yellow/Red	80-ZA183-YR
L-850D	Threshold/End	Bidirectional	2	Green/Red	80-ZA188-GR
			1	Green/Blank	80-ZA188-GX
			2	Red/Red	80-ZA188-RR

Ordering Codes

L-850C Runway Edge	Color (LH)	Color (RH)	Plug Leads	Lamps	Bypass
80-ZA183	W: White Y: Yellow G: Green R: Red X: Blank	W: White Y: Yellow G: Green R: Red X: Blank	1: Single Hi-temp 2: Two Hi-temp	1: Single 105W 2: Two 105W	B: Lamp bypass Blank: No bypass

L-850D Thld/End	Color Configuration	Plug Leads	Lamps	Bypass
80-ZA188	GRL: Green/Red (Green Toe Left, Red Axial) RGR: Red/Green (Red Axial, Green Toe Right) RRL: Red/Red (Red Toe Left, Red Axial) RRR: Red/Red (Red Axial, Red Toe Right) GXL: Green/Blank (Green Toe Left, Blank Axial) XGR: Blank/Green (Blank Axial, Green Toe Right)	1: Single Hi-temp 2: Two Hi-temp	1: Single 105W 2: Two 105W	B: Lamp bypass Blank: No bypass

NOTE: See page 2 for L-850C & D Toe Determination. Fixture includes adapter/flange for mounting on L868B.

Visit our web site: www.flightlight.com



Flight Light Inc.
 2708 47th Ave.
 Sacramento, California, U.S.A.
 95822-3806

PH (916) 394-2800
 TF (800) 806-3548

FX (916) 394-2809
 EM info@flightlight.com

atg airports (formerly ALSTOM)
 ZA183, ZA188 High Intensity
 Runway Edge, Threshold and
 End Inset Light
 FAA Compliant: L-850C & D,
 NATO Stanag 3316, ICAO Annex 14

L-850C & D Toe Determination

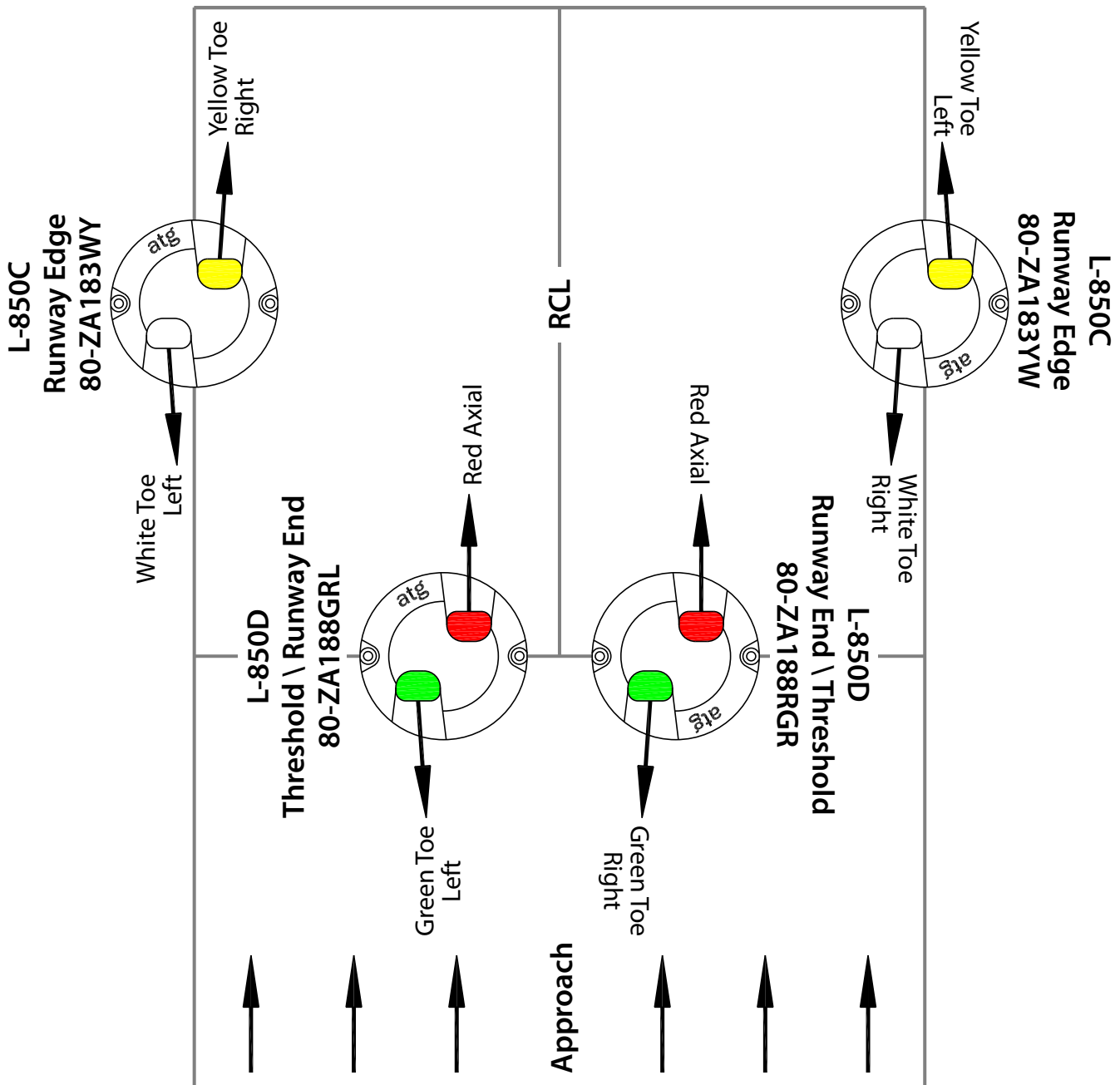

NOTE: For Runway Edge Lights (L-850C), the 'atg' in the body casting should be readable from the runway centerline.

Visit our web site: www.flightlight.com



Flight Light Inc.
2708 47th Ave.
Sacramento, California, U.S.A.
95822-3806

PH (916) 394-2800 FX (916) 394-2809
TF (800) 806-3548 EM info@flightlight.com

atg airports (formerly ALSTOM)
ZA183, ZA188 High Intensity
Runway Edge, Threshold and
End Inset Light
FAA Compliant: L-850C & D,
NATO Stanag 3316, ICAO Annex 14

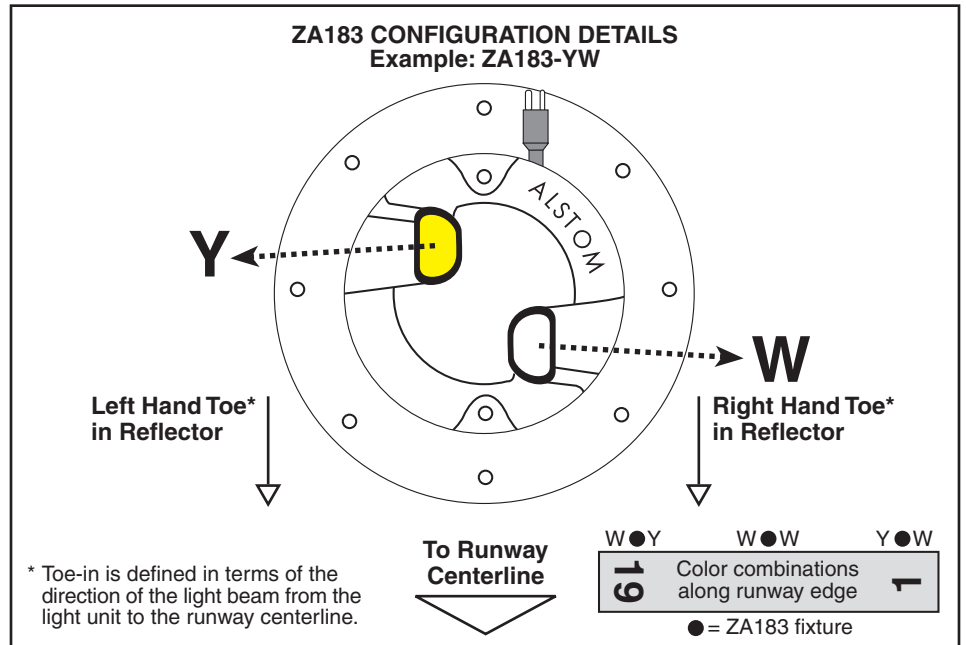
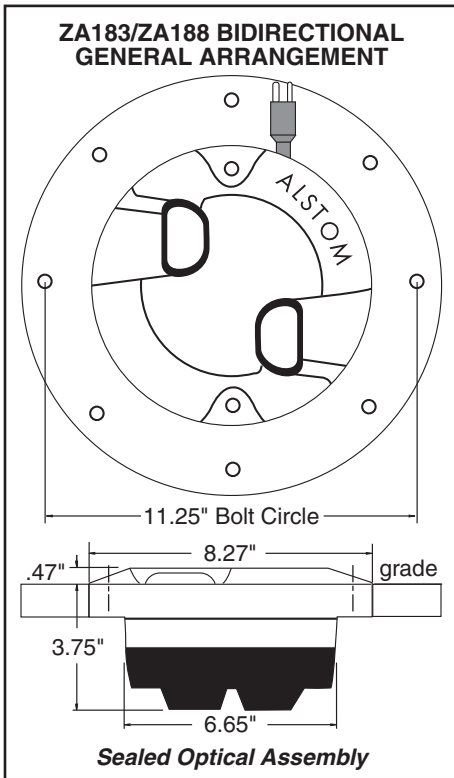

Common Replacement Parts

1	Body casting (anodized gray)	80-040090
2/3	White (clear) prism	80-016069
2/3	Red dichroic prism	80-019141
2/3	Blank for prism aperture	80-040092
4	Prism gasket	80-033058
5	Prism retaining clamp	80-032037
6	Lampholder	80-032040
7	Lamp retaining spring	80-032039
8	Lamp, MR16, 6.6A, 105W	80-008072
9	Connector/by-pass block assy (ZA181)	80-031030
10	105W by-pass disc	80-021135
11	Hi-temp lead	80-013026
12	Base casting (single lead)	80-040091
NS	Base casting (twin lead)	80-040093
13	Cable gland assembly	80-021114/5/6
14	'O' ring seal	80-033059
15	Lamp gasket	80-033064
16	Prism clamp gasket	80-028918
17	Lampholder support block	80-029057
NS	12" FAA L-868B axial mounting adapter	80-009078
NS	12" FAA L-868B left toe mounting adapter	80-009079
NS	12" FAA L-868B right toe mounting adapter	80-009080

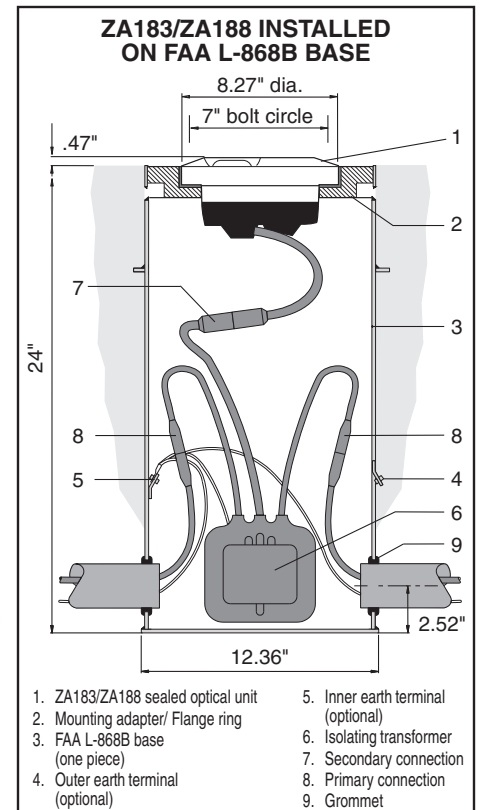
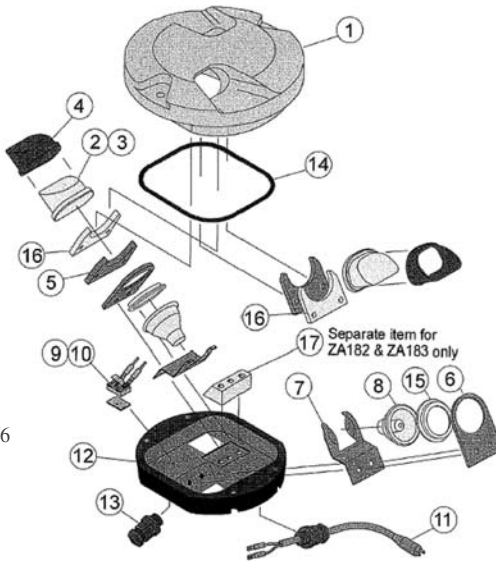

Visit our web site: www.flightlight.com