



OPERATION MANUAL

FL-81011

FL-81011-B

LAMP ALARM/TRANSFER RELAY MODULE

INPUT VOLTAGE: 120VAC

THIS MANUAL CONTAINS IMPORTANT PERFORMANCE, MAINTENANCE AND SAFETY INFORMATION. PLEASE READ THE MANUAL BEFORE INSTALLING THE LIGHT SYSTEM, AND KEEP THE MANUAL HANDY FOR FUTURE REFERENCE

PART II

SAFETY MEASURES

Ensure power is off before installing or servicing lighting controller!

Follow the local electrical code!

Make sure the equipment is rated and approved for the environment in which you are intending to use it. Do not operate this equipment in humid, flammable, or explosive environments unless it has been rated for safe operation in these environments.

Use only electrical wire of sufficient gauge and insulation to handle the rated current and voltage demand.

Route electrical wiring along a protected path. Make sure they will not be damaged by moving equipment.

Protect components from harsh environment conditions.

Protect equipment with safety devices as specified by applicable safety regulations.

Before starting this equipment, check all safety interlocks, fire –detection systems, and protective devices such as panels and covers. Make sure all devices are fully functional. Do not operate the system if these devices are not working properly.

Never operate equipment with a known malfunction.

Do not attempt to operate or service electrical equipment if standing water is present.

Do not touch exposed electrical connections on equipment while the power is ON!

Wiring and electrical design should be authorized by an electrical contractor.

PART III

WIRING DIAGRAM

OBSTRUCTION LAMPS WIRING DIAGRAM

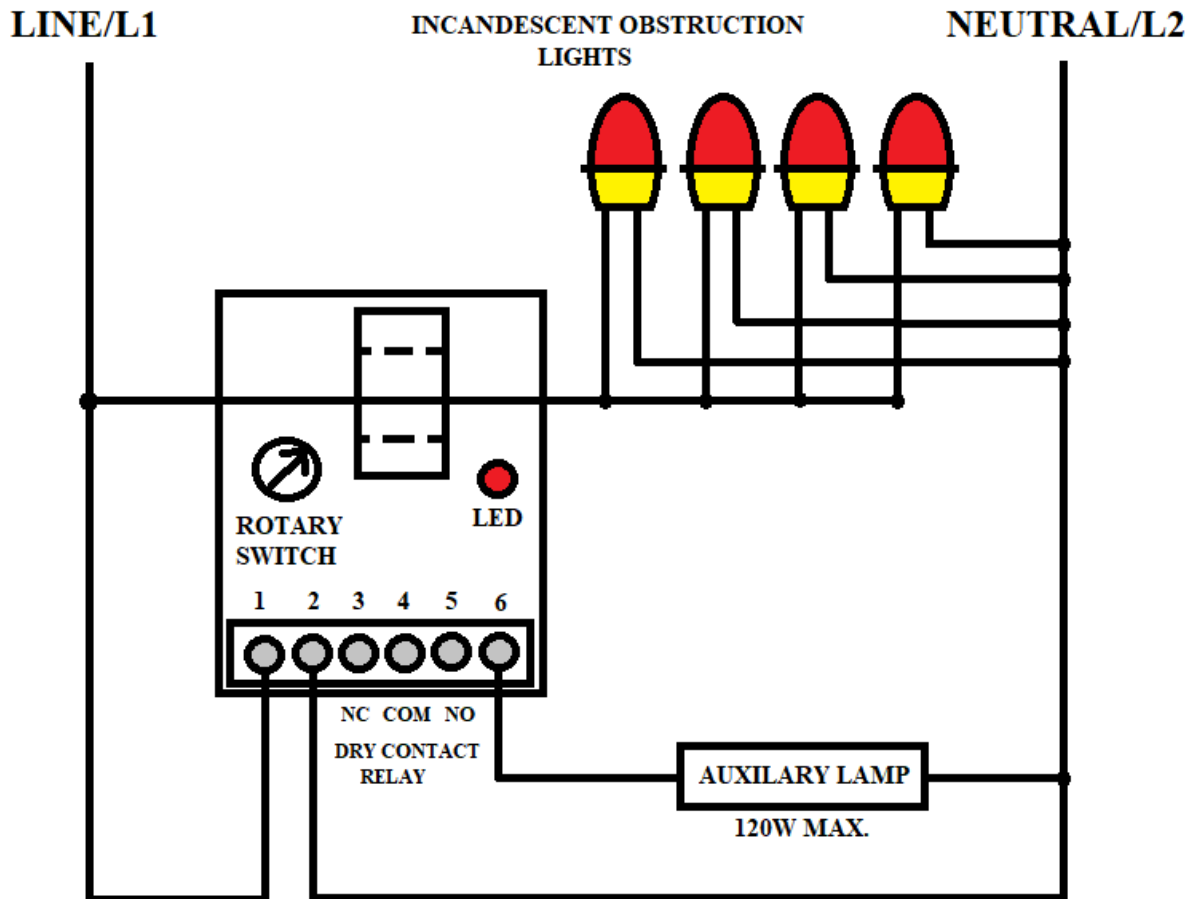

TERMINAL BLOCK

1. LINE/L1
2. NEUTRAL/L2
3. NORMALLY CLOSED (NC)
4. COMMON (COM)
5. NORMALLY OPEN (NO)
6. AUXILARY LAMP (120W MAX.)

OBSTRUCTION LAMPS AND BUZZER WIRING DIAGRAM

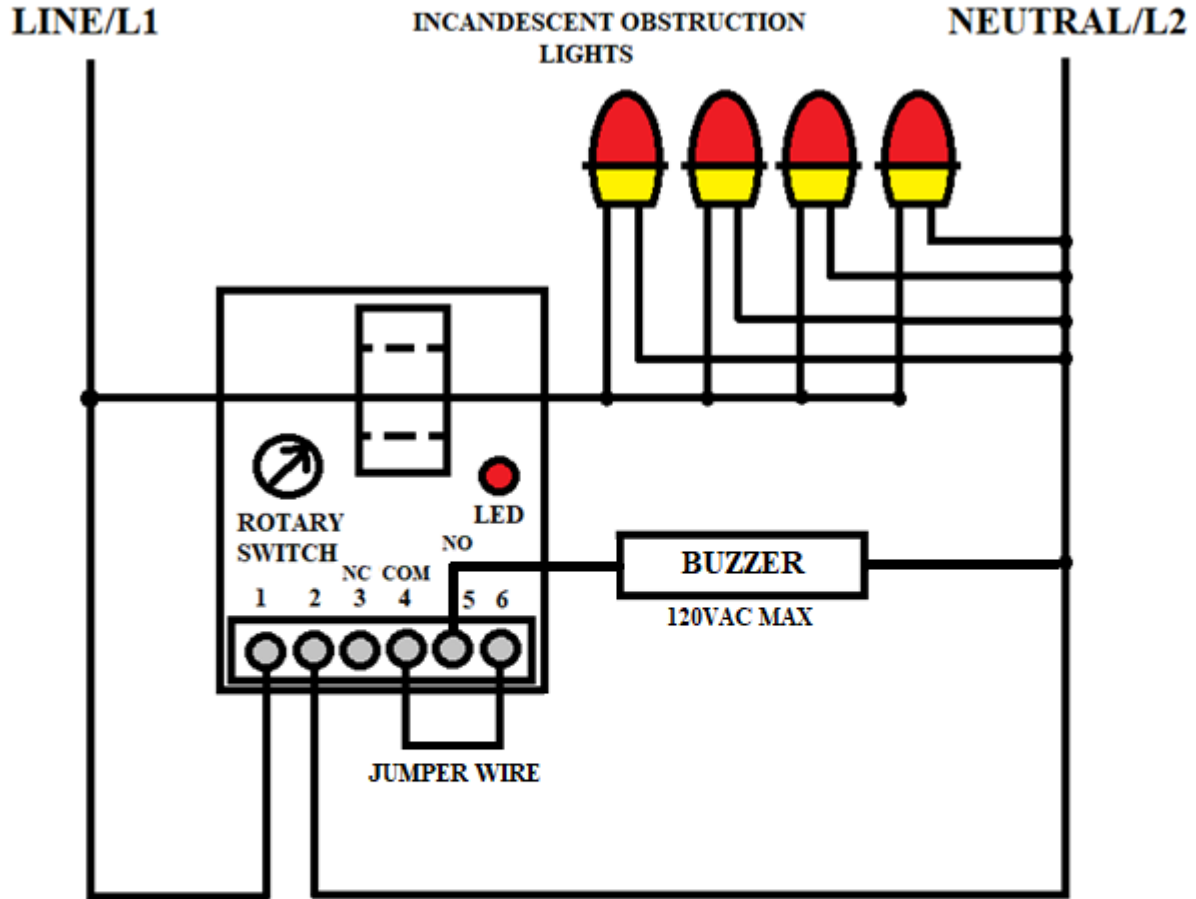

TERMINAL BLOCK

1. LINE/L1
2. NEUTRAL/L2
3. NORMALLY CLOSED (NC)
4. COMMON (COM)
5. NORMALLY OPEN (NO)
6. AUXILARY LAMP (120W MAX.)

PART IV

CIRCUIT CALIBRATION

Step 1. The circuit needs to be calibrated to the amount of lights connected to the circuit (Maximum 9 light fixtures). To calibrate, connect the fixtures to the circuit. Connect the light fixtures and alarmed devices to the FL-81011 module per the wiring diagram (See pg. 3).

Step 2. , For incandescent L-810 light fixtures (116W each), feed the wire thru the toroidal transformer and do a one loop of wiring on the toroidal transformer. (See Photo 1).

One wire loop
on toroidal
transformer for
L-810 Fixtures
Only

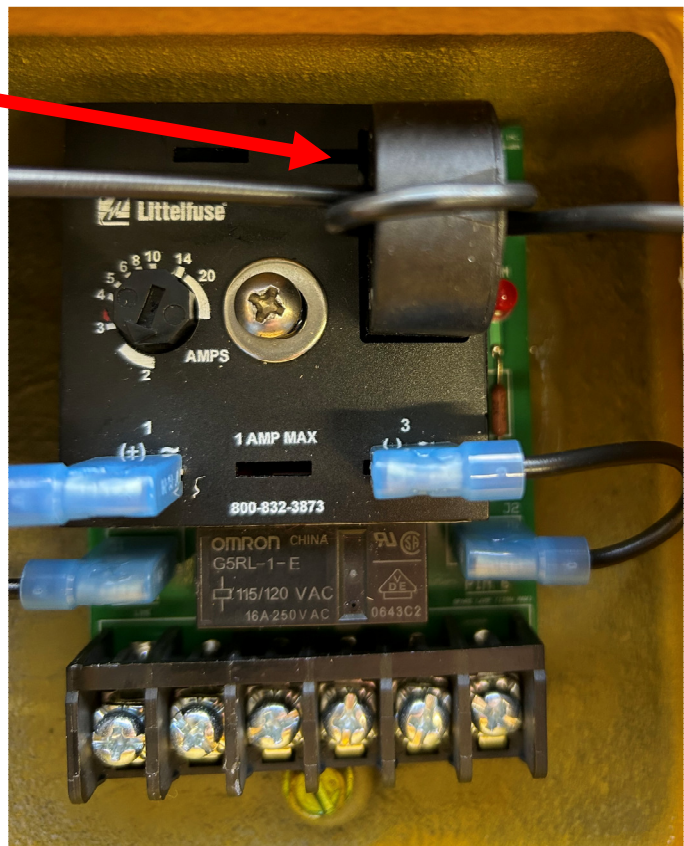

PHOTO 1 (Incandescent Light Fixture Toroidal Transformer Wiring)

Step 3. turn ON the power to the module with the circuit breaker and verify that the obstruction light fixtures. With the light fixtures powered ON, to calibrate slowly rotate the Rotary Switch clockwise until the CALIBRATION LED turns brighter. As soon as the CALIBRATION LED turns brighter, stop rotating the switch. (See Photo 2)

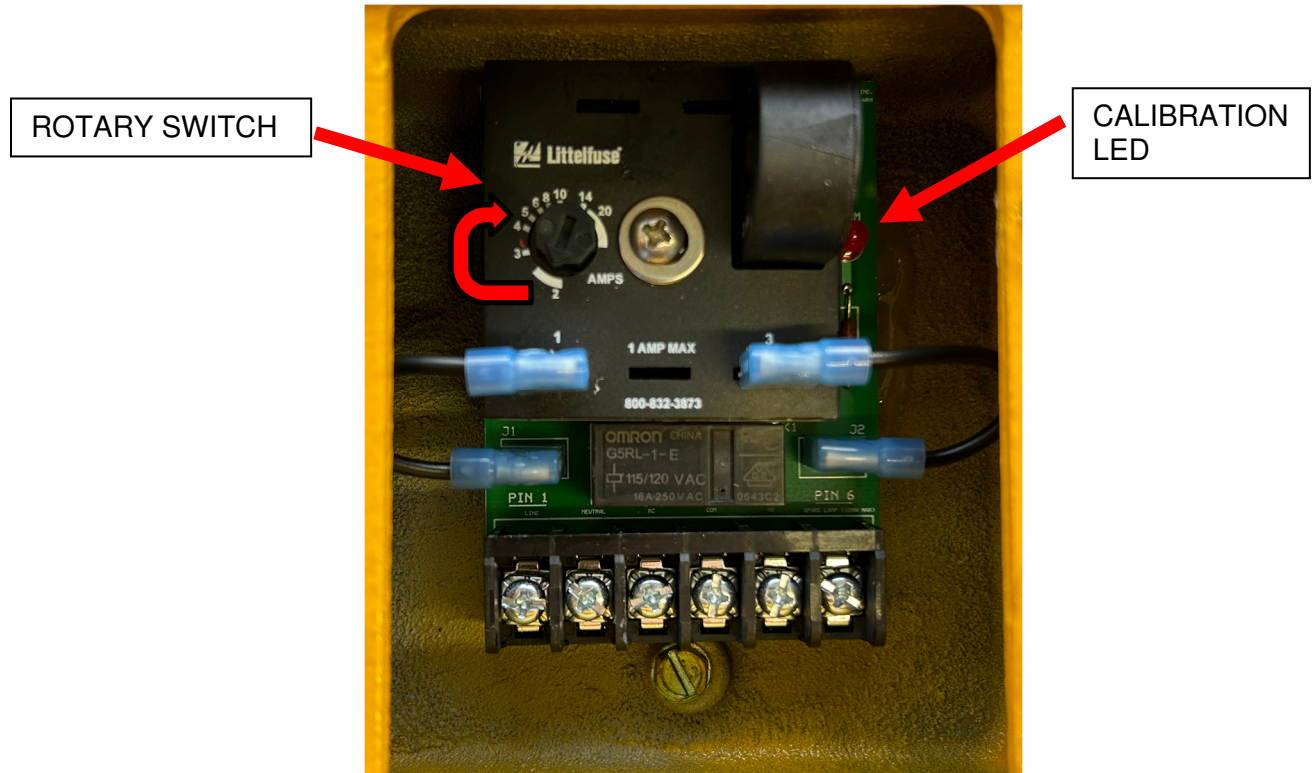

PHOTO 2

Step 4. With the CALIBRATION LED turned on brighter, now very slowly and gently turn the rotary switch counterclockwise until the CALIBRATION LED turns dimmer. As soon as the CALIBRATION LED turns dimmer and you hear a click, stop rotating the rotary switch. The circuit is now calibrated to the number of lights connected. Maximum nine (9) single incandescent obstruction light fixtures. See PHOTO 3.



PHOTO 3

Step 5. To test, you can momentarily disconnect a light fixture to simulate a failure, to verify that the dry contact relay gets energized and changes state and that PIN 6 (Auxiliary Lamp) becomes energized with 120VAC. Once you connect back the light fixture that you disconnected, the dry contact relay will become deenergized and PIN 6 (Auxiliary Lamp) will become deenergized as well.

PART V
TECHNICAL SUPPORT

Please contact Flight Light customer service if you have any questions or require warranty service.



2708 47th Avenue
Sacramento, CA 95822

1-800-806-3548 (US)
001-916-394-2800 (Intl)

sales@flightlight.com