

# ZA280C | L-852C

## 8" Taxiway Centerline, Straight Sections (Narrow), High Intensity Lighting Solutions

### Compliance and Applications

- FAA Certified: L-852C (AC 150/5345-46)
- ICAO Annex 14, Vol 1
- IEC 61827
- EASA
- Stanag 3316 (NATO)

The ZA280C is a high intensity, inset taxiway centerline (narrow straight sections) fixture with a narrow beam, suitable for CAT III all weather operation airfield ground lighting (agl) systems.

The fixture may be used in 6.6A airfield lighting circuits normally supplied from 1 x 45W, 1 x 65W or 100W isolating transformer. Power consumption is normally 48W.

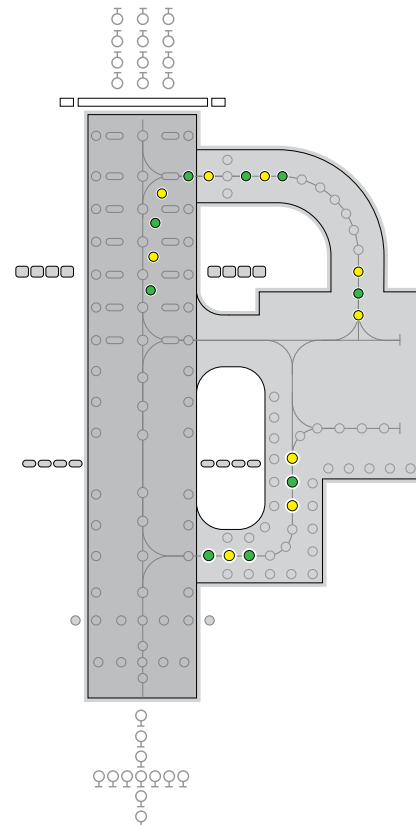
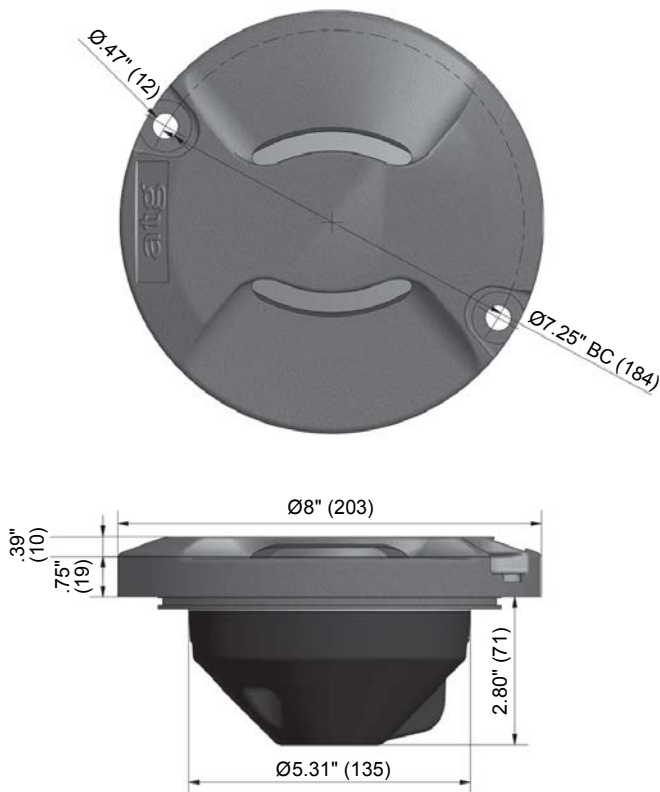



Ordering Codes

IL-ZA280 C

**Application**  
L-852C Taxiway Centerline  
Straight (Narrow)

**Color**  
**A Side**  
G = Green  
Y = Yellow  
X = Blank  
**B Side**  
G = Green  
Y = Yellow  
X = Blank

**Specification**  
1 = FAA  
2 = ICAO

**Connections**  
1 = 1 Bi Pin Plug  
2 = 2 Bi Pin Plug

Additional optional features are available upon request.

Packaging

- Net weight: 6.6 lb. (3Kg)
- Gross weight: 7.7 lb. (3.5Kg)
- Box: 9.1" (230mm) (w) x 9.1" (230mm) (d) x 5.7" (146mm) (h)

Common Replacement Parts

1. Body casting
2. Prism clamp 80-021268
3. Prism clamp gasket 80-033072
4. Prism gasket (2) 80-033071
5. Glass prisms (1 or 2)  
white (clear) 80-016072  
blank 80-040102
6. 48w 6.6a MR16 lamp LA-008065
7. Lamp gasket 80-033064
8. Filter  
red 80-019155  
green 80-019156  
yellow 80-019157  
blue 80-019201
9. Lamp retaining spring 80-032039
10. Bottom cover
11. Bottom cover gasket 80-033080
12. 'B' type plug lead 80-013001
13. Cable gland assembly 80-021114/5/6

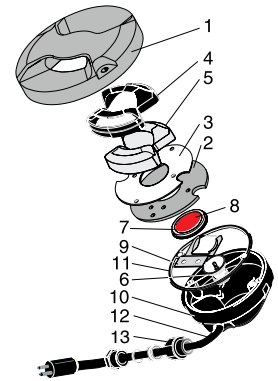

ZA280 Installed on FAA L-868 Base

1. ZA280 fixture
2. Adapter ring (BA-AA122820)
3. FAA L-868 base (one piece)
4. Outer earth terminal (optional)
5. Inner earth terminal (optional)
6. Isolating transformer
7. Secondary connection
8. Primary connection
9. Grommet

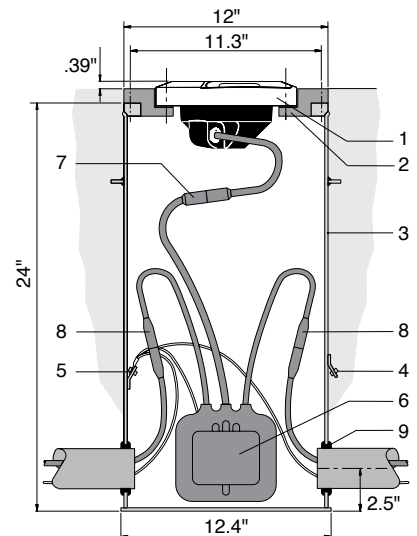

Beam Options

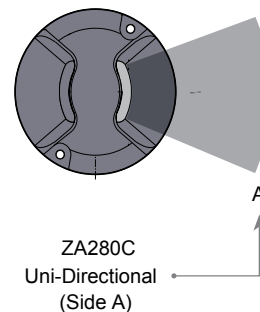
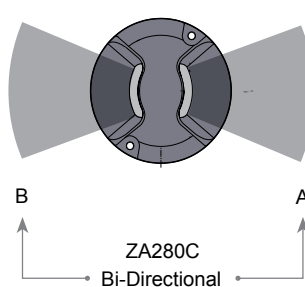
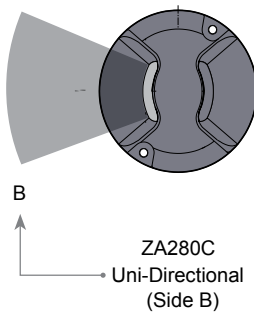

+1.800.806.3548 USA  
+1.916.394.2800 Worldwide

[www.flightlight.com](http://www.flightlight.com)  
[sales@flightlight.com](mailto:sales@flightlight.com)

Flight Light Inc., 2708 47th Ave.  
Sacramento, CA, 95822, USA



## Electrical Performance

Main Beam Aperture		Color	Power Consumption Watts (VA) @ 6.6A
Horiz(°)	Vert(°)		
-3.5 to +3.5	1 to 8	GRN/GRN	48W
-3.5 to +3.5	1 to 8	YEL/YEL	48W
-3.5 to +3.5	1 to 8	GRN/YEL	48W
-3.5 to +3.5	1 to 8	GRN/BLK	48W
-3.5 to +3.5	1 to 8	YEL/BLK	48W

Fixture Operational Current Range: 2.7 to 6.7A RMS

\* as measured at the input leads of the fixture.

\*\* as measured across the primary winding of an appropriately sized isolation transformer with a total fixture and transformer secondary length not exceeding ~72" (1.85m).

Note: Isolating transformer shall be suitably sized to accommodate specific secondary and other applicable losses.

For bi-directional twin lead option use unidirectional electrical performance for each direction.

## Environmental Conditions

- Ambient Temperature -67 °F to +131°F (-55 °C to +55°C)
- Storage Temperature -67 °F to +131°F (-55 °C to +55°C)
- Ingress Protection IP67

## Photometry

### Specification

**Taxiway Centerline - Straight Narrow ICAO Fig A2-13 FAA L-852C**

Color	Green
Max/Min Intensity Ratio	<3.0
Main rect. average intensity	200 cds
Main rect. minimum intensity	100 cds
Second rect. minimum intensity	20 cds

### Typical Measured Values

**Taxiway Centerline - Straight (Narrow) Green**

Color	Green
Max/Min Intensity Ratio	2.59
Main rect. average intensity	400 cds
Main rect. maximum intensity (A)	512 cds
Main rect. minimum intensity (B)	197 cds
Second rect. minimum intensity	120 cds

### Specification

**Taxiway Centerline - Straight (Narrow) Yellow**

Color	Yellow
Max/Min Intensity Ratio	<3.0
Main rect. average intensity	200 cds
Main rect. minimum intensity	100 cds
Second rect. minimum intensity	20 cds

### Typical Measured Values

**Taxiway Centerline - Straight (Narrow) Yellow**

Color	Yellow
Max/Min Intensity Ratio	1.96
Main rect. average intensity	462 cds
Main rect. maximum intensity (A)	584 cds
Main rect. minimum intensity (B)	299 cds
Second rect. minimum intensity	228 cds

Intensity Chart - Taxiway Centerline Luminaire (straight narrow) Green

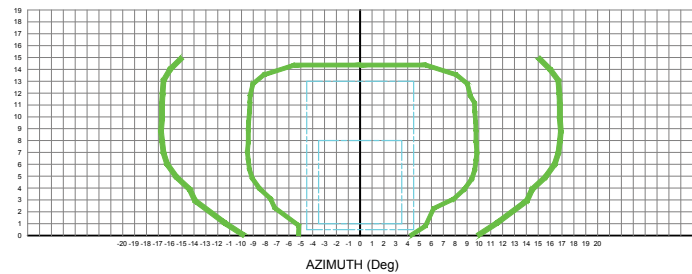

Intensity Chart - Taxiway Centerline Luminaire (straight narrow) Yellow

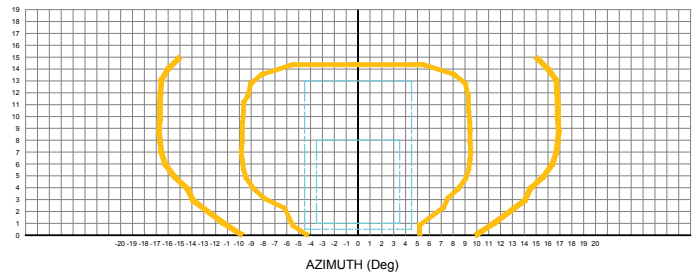

### L-867 to 8" One Piece Adapter Ring (30-86712-25)

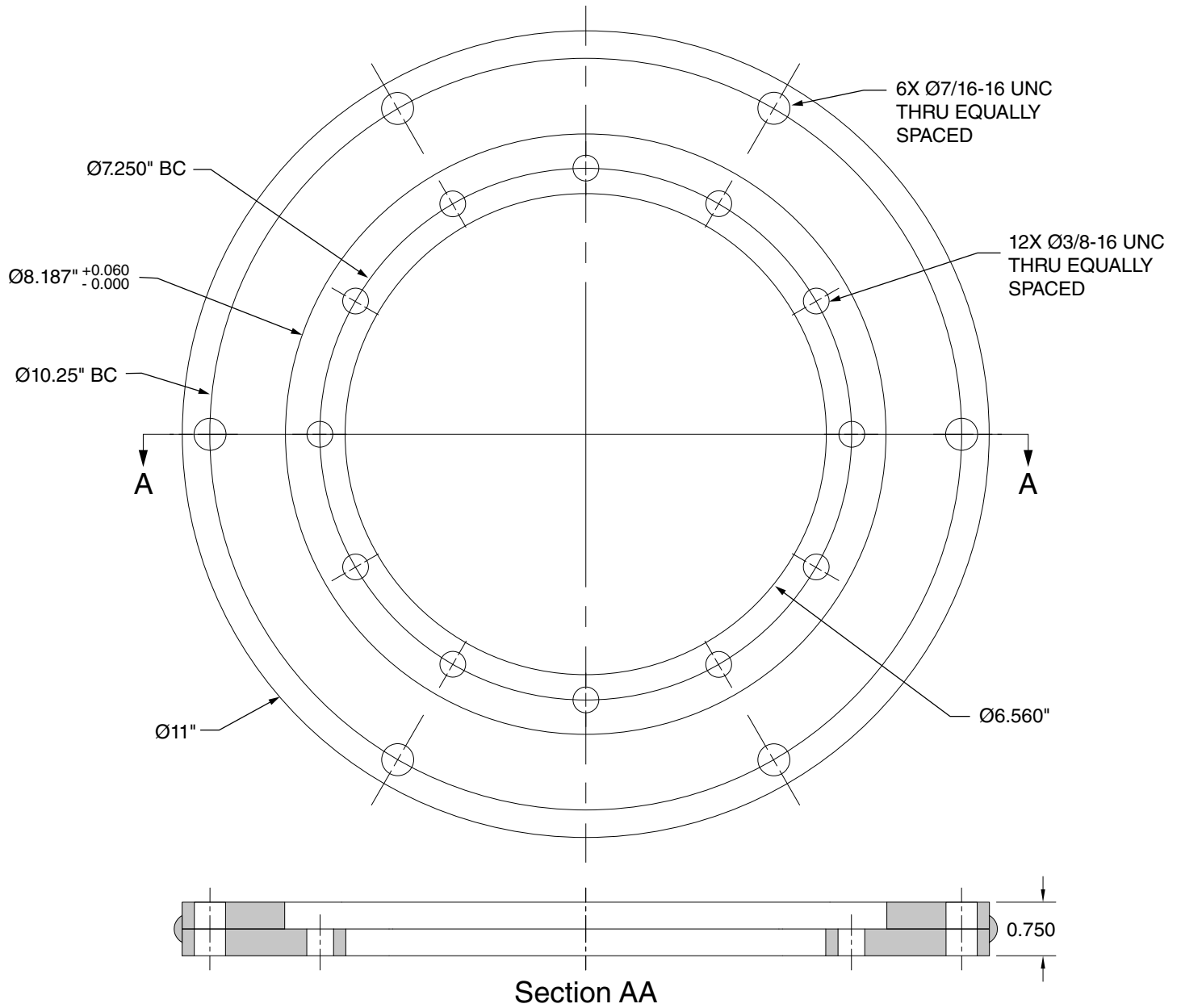

# Adapter Ring for 12" L-868B Base Can to 8" Inset Fixture

## Compliance and Applications

Certified to FAA AC 150/5345-42 (Current Revision), Size: B=12"

Adapter ring for mounting 8" diameter (7.25" BC) inset fixture to 12" L-868B base can.

## Specifications

- Ductile iron castings with a black powder coat finish
- (6) 7/16" Ø equally spaced, thru holes with 1-1/8" Ø x 1/2" deep counter bore
- (6) 3/8" -16 tapped holes
- Adapter rings are shipped with:
  - (2) 3/8" -16 x 1-1/4" stainless hex head cap screws
  - (2) 3/8", 2 piece locking washers
  - (1) Bolt Set containing:
    - + (6) 3/8" -16 x 1" stainless hex head cap screws
    - + (6) 3/8", 2 piece locking washers

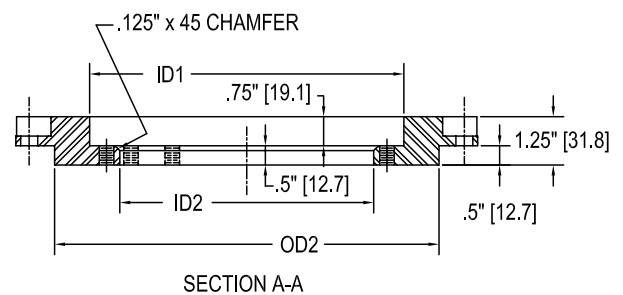
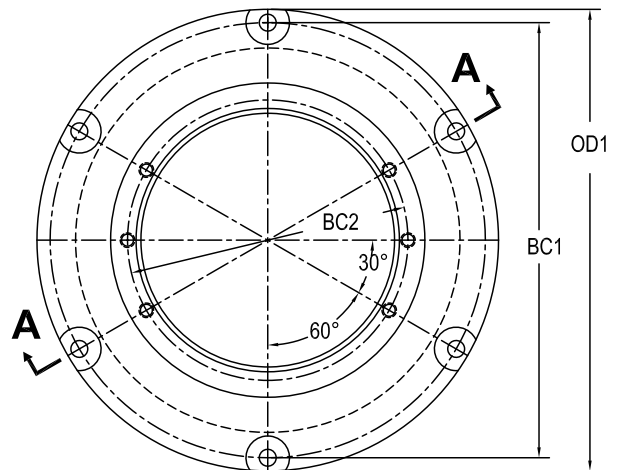

## Ordering Codes

Part #	OD1	BC1	OD2	ID1	BC2	ID2
<b>BA-AA122820</b> 12" L-868B	11.938" (303.2)	11.25" (285.8)	9.938" (252.4)	8.125" (206.4)	7.25" (184.2)	6.563" (166.7)

(length in mm)

+1.800.806.3548 USA  
+1.916.394.2800 Worldwide

[www.flightlight.com](http://www.flightlight.com)  
[sales@flightlight.com](mailto:sales@flightlight.com)

Flight Light Inc., 2708 47th Ave.  
Sacramento, CA, 95822, USA