

# IR852T | L-852T(L)

## IRIS LED 8" Taxiway and Apron Edge, Omni-Directional, High Intensity Lighting Solutions

### Compliance and Applications

- FAA Certified: L-852T(L)(FAA AC 150/5345-46)
- ICAO Annex 14. Vol 1
- FAA Engineering Brief No. 67
- IEC 61827
- EASA
- Stanag 3316 (NATO)

IRIS LED high intensity, omni-directional taxiway and apron edge fixture suitable for CAT III all weather operation airfield ground lighting (agl) systems. The goal of the IRIS range is to enhance the efficiency of an airfield by optimizing power consumption, increasing reliability and reducing costs to the airport.

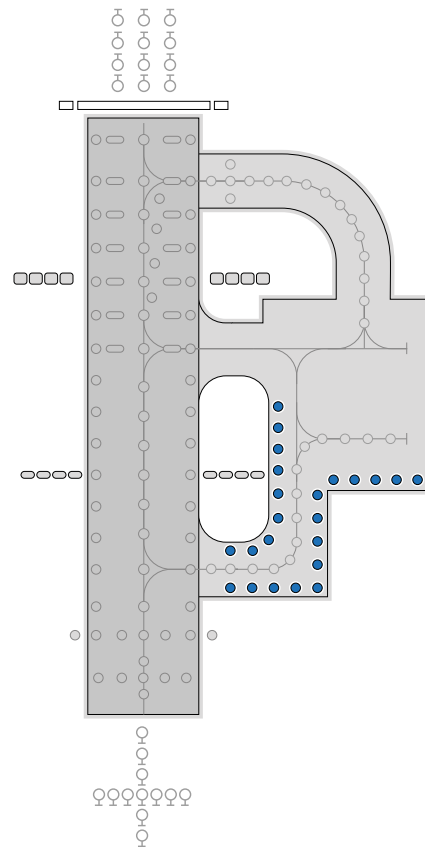
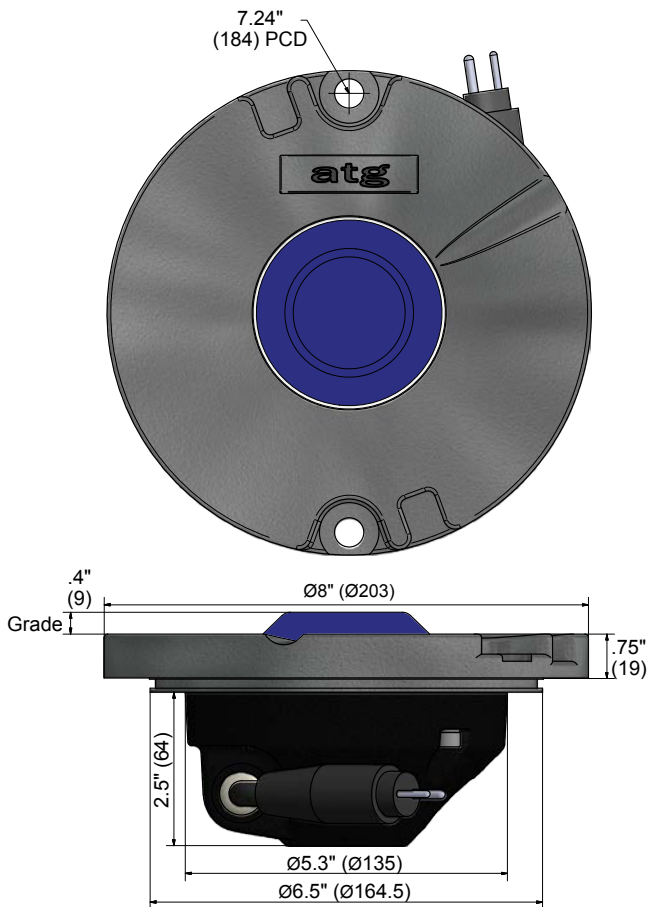

+1.800.806.3548 USA  
+1.916.394.2800 Worldwide

[www.flightlight.com](http://www.flightlight.com)  
[sales@flightlight.com](mailto:sales@flightlight.com)

Flight Light Inc., 2708 47th Ave.  
Sacramento, CA, 95822, USA

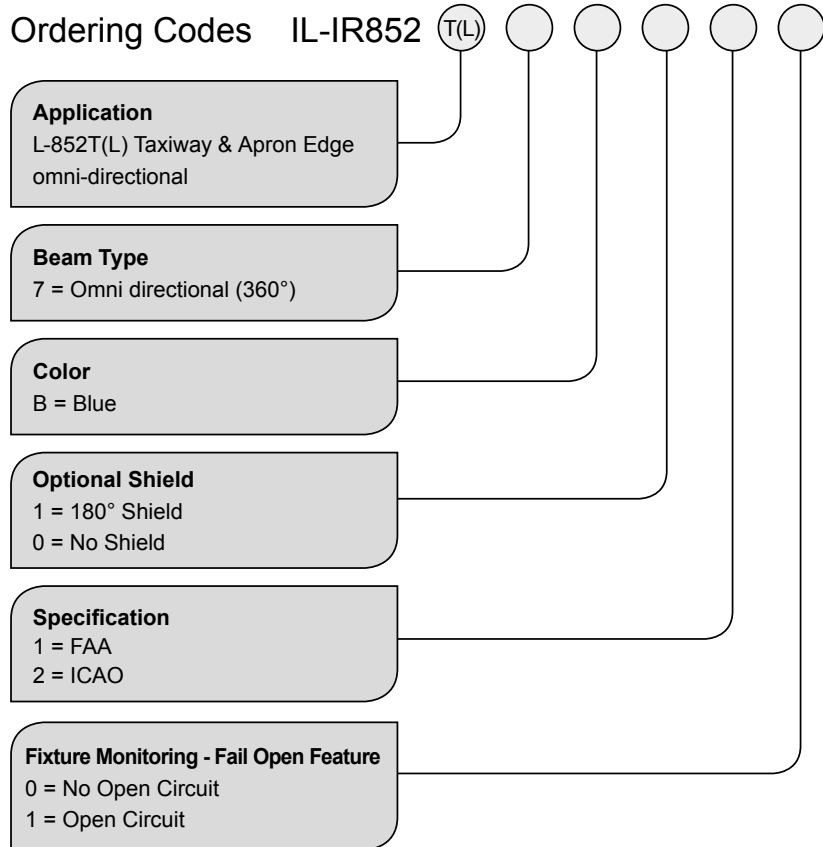

Beam Options

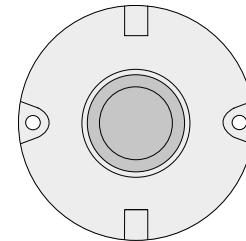

IR852T(L)  
Omni Directional 360°

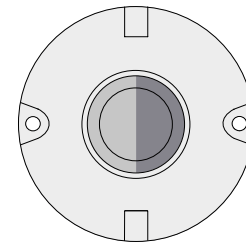

IR852T(L)  
Omni Directional  
with 180° Shield

\* Other seating/mounting configurations are available on request.

**Packaging**

- Net weight: 6.6 lb. (3Kg)
- Gross weight: 7.7 lb. (3.5Kg)
- Box: 10" (254mm) (w) x 10" (254mm) (d) x 10" (254mm) (h)



## Electrical Performance

Main Beam Aperture		Color	Typical Power Consumption - Watts (VA) @ 6.6A					
Horiz(°)	Vert(°)		Per Beam Watts	Fixture*		Tx Primary**		Isolating Transformer
				Watts (VA)	PF	Watts (VA)	PF	
0-359	0-6	Blue	0.75	4.71 (4.74)	0.993	12.87 (13.01)	0.991	10W
0-359	0-6	Blue	0.75	4.67 (4.70)	0.993	13.76 (14.09)	0.977	25W
0-359	0-6	Blue	0.75	4.64 (4.66)	0.994	16.23 (17.16)	0.948	45W

Fixture Operational Current Range: 2.7 to 6.7A RMS

Notes: Isolating transformer shall be suitably sized to accommodate specific secondary and other applicable losses.

\* as measured at the input leads of the fixture.

\*\* as measured across the primary winding of an appropriately sized isolation transformer with a total fixture and transformer secondary length not exceeding - 1.85m (72"). CCR shall be suitably sized for the indicated transformer VA for the relevant isolating transformer utilized.

\*\*\* main beam vertical requirements for FAA is 1° to 6° for IR852T

## Environmental Conditions

▶ Ambient Temperature -55 °C to +55°C (-67 °F to +131°F)

▶ Ingress Protection IP67

▶ Storage Temperature -55°C to +55°C (-67 °F to +131°F)

### Photometry

**Specification**

Taxiway & Apron Edge omni-directional ICAO - 5.3.18.7/8 FAAL-852T	
Color	Blue
Main rect. minimum intensity 0°-6°	2 cd
Second rect. minimum intensity 6°-90°	0.2 cd

**Typical Measured Values**

Color	Blue
Main rect. minimum intensity 0°-6°	3.0 cd
Main rect. minimum intensity 0°-8° (Stannag)	2.9 cd
Second rect. minimum intensity 6°-90°	1.0 cd

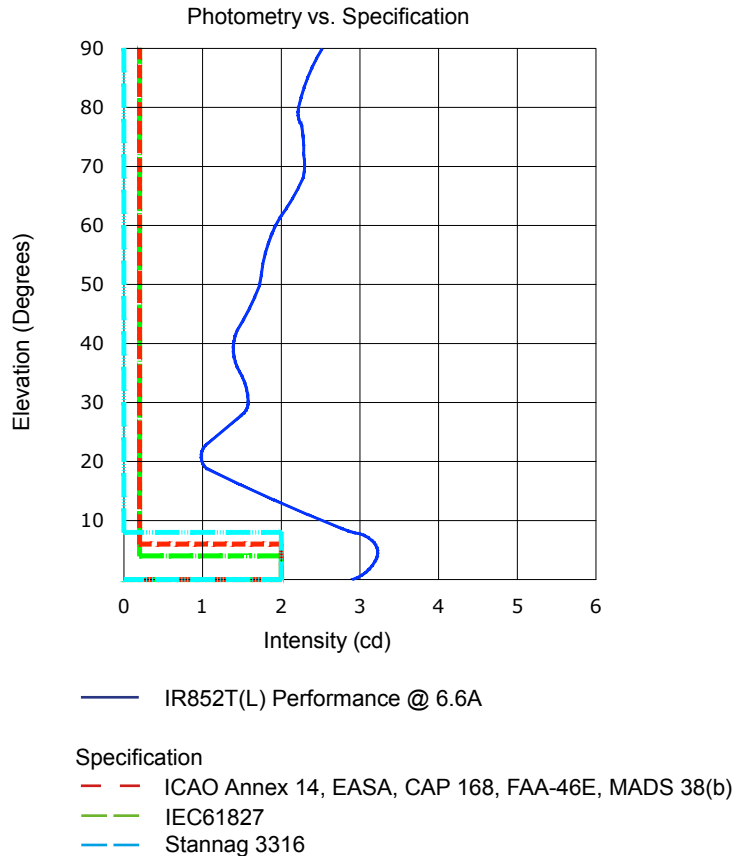

### L-867 to 8" One Piece Adapter Ring (30-86712-25)

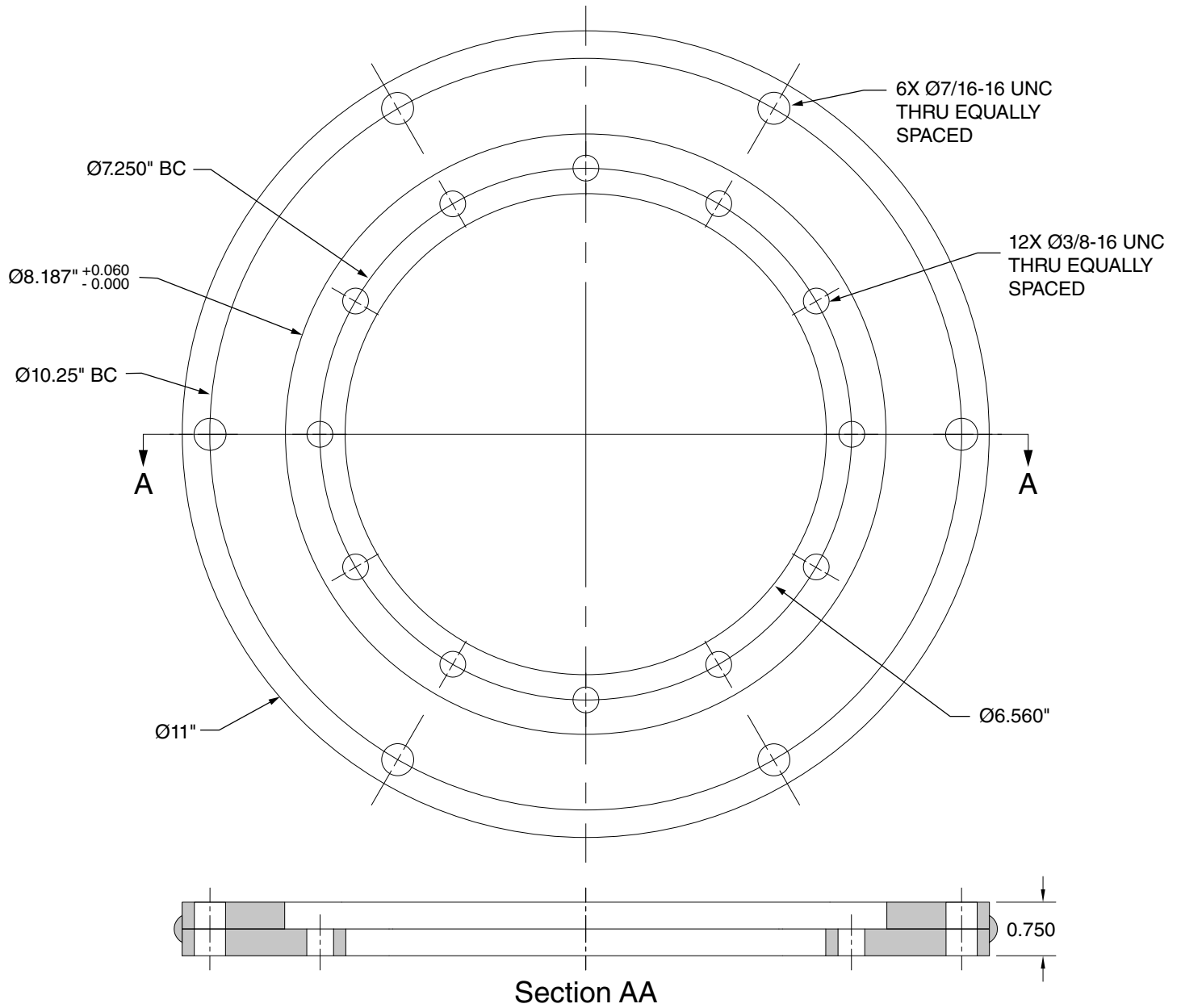

# Adapter Ring for 12" L-868B Base Can to 8" Inset Fixture

## Compliance and Applications

Certified to FAA AC 150/5345-42 (Current Revision), Size: B=12"

Adapter ring for mounting 8" diameter (7.25" BC) inset fixture to 12" L-868B base can.

## Specifications

- Ductile iron castings with a black powder coat finish
- (6) 7/16" Ø equally spaced, thru holes with 1-1/8" Ø x 1/2" deep counter bore
- (6) 3/8"-16 tapped holes
- Adapter rings are shipped with:
  - (2) 3/8"-16 x 1-1/4" stainless hex head cap screws
  - (2) 3/8", 2 piece locking washers
  - (1) Bolt Set containing:
    - + (6) 3/8"-16 x 1" stainless hex head cap screws
    - + (6) 3/8", 2 piece locking washers

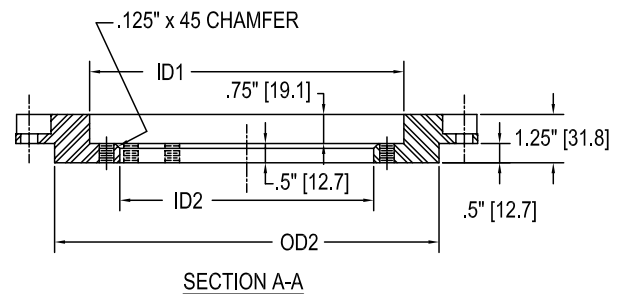
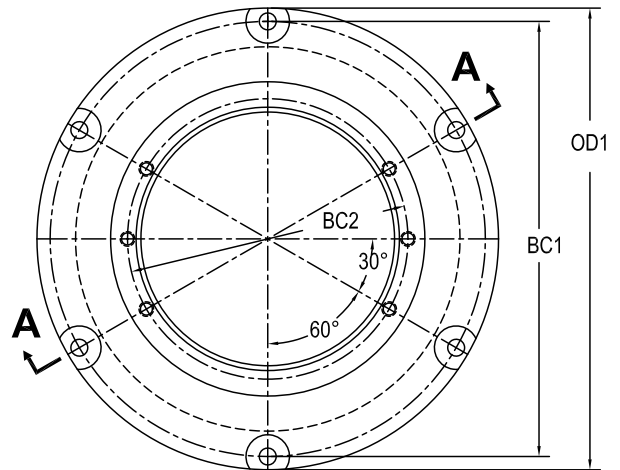

## Ordering Codes

Part #	OD1	BC1	OD2	ID1	BC2	ID2
<b>BA-AA122820</b> 12" L-868B	11.938" (303.2)	11.25" (285.8)	9.938" (252.4)	8.125" (206.4)	7.25" (184.2)	6.563" (166.7)

(length in mm)

+1.800.806.3548 USA  
+1.916.394.2800 Worldwide

[www.flightlight.com](http://www.flightlight.com)  
[sales@flightlight.com](mailto:sales@flightlight.com)

Flight Light Inc., 2708 47th Ave.  
Sacramento, CA, 95822, USA