

L-868 Class 1B Light Base

Compliance and Applications

Certified to FAA AC 150/5345-42 (Current Revision)
 L-868 Class 1B; Size: A=8", Size: B=12", Size: C=15"

Our FAA approved, load bearing light bases are designed for locations which experience aircraft and other heavy vehicular loading. The base typically supports an in-pavement light fixture and houses a powering isolation transformer. It can also be used solely as a junction box or transformer housing.

Specifications

- Material:
 - SS: All stainless steel construction (12 GA min, 304/18-8)
 - SB: Steel base (.109" min) with VEGA-KOTE coating and stainless steel top ring
- Mounting holes:
 - Size: A: (4) 3/8-16 holes at 60°, 120°, 240°, 300°
 - Size: B, C: (12) 3/8"-16 equally spaced, tapped holes are located over conduit openings
- (6) 3/8-16 x 1" stainless hex head cap screws
- Conduit openings are:
 - 2.5" up from bottom
 - Various sizes and locations are available
 - Protective plug installed in threaded hubs
 - Flex Connex Grommets are shipped separately
- Internal/External ground straps are standard
- Diameter: A=8" (7.25" BC), B=12" (11.25" BC), C=15" (14.25" BC)
- Height: 24"
- 3/4" plywood cover

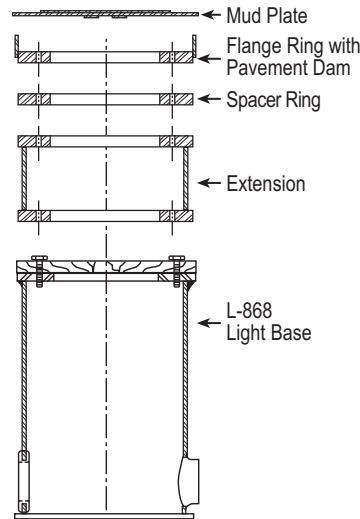
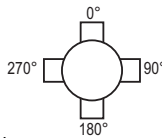

Dimensions

Base Type	BOD	TOD	TBC	TID	A
8" L-868A	9.5" (241.3)	8.5" (215.9)	7.25" (184.2)	6.5" (165.1)	10" (254)
12" L-868B	13.5" (342.9)	12.5" (317.5)	11.25" (285.8)	10" (254)	14" (355.6)
15" L-868C	16.5" (419.1)	15.5" (393.7)	14.25" (362)	13" (330.2)	17" (431.8)

(length in mm)

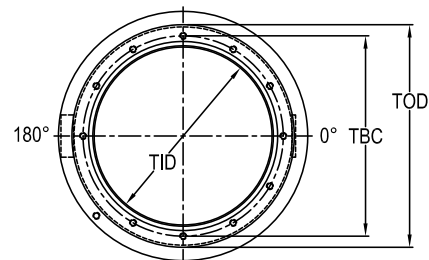

Ordering Codes

Base Type	Conduit Opening Type	Conduit Locations	Ground Strap*	Drain Hole	Material
BA-L868A: 8" L-868A	G: Grommets for 2" PVC	1: 0° 2: 0°, 180°	O: None I: Internal	O: None D: 3/4" hole	SS: All stainless steel construction SB: Steel base with coating and stainless steel top ring
BA-L868B: 12" L-868B	H: Hubs for 2" PVC	3: 0°, 90°, 180°	E: External	E: 1" hole	
BA-L868C: 15" L-868C	J: Special grommet size K: Special hub size	4: 0°, 90°, 180°, 270° S: Specify	Q: Internal & External	S: Specify	

* Ground required for FAA approval

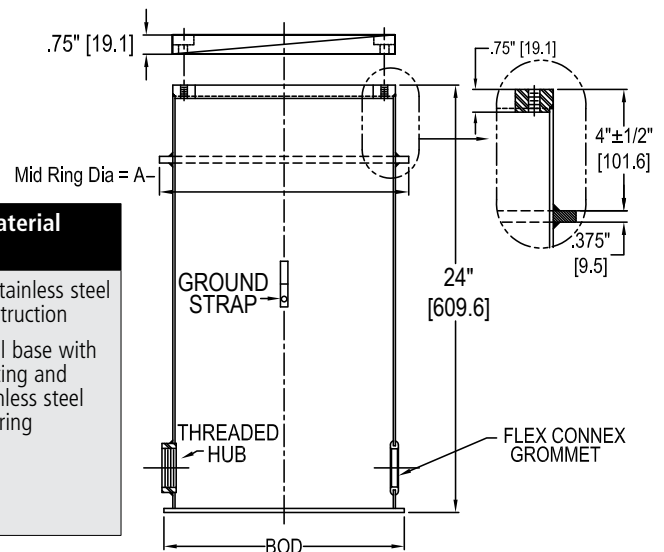

+1.800.806.3548 USA
 +1.916.394.2800 Worldwide

www.flightlight.com
sales@flightlight.com

Flight Light Inc., 2708 47th Ave.
 Sacramento, CA, 95822, USA



Copper Ground Clamp & Lug for Base Cans

Applications

Copper clamp for attaching copper cable to base can ground strap. Stainless steel hardware.

Specifications

- Material: copper
- Hardware:
 - 5/16" -18 x 1-1/4" SS HHCS
 - 5/16" -18 SS Wiz-Lock Nut
 - 1/4" -20 x 1" SS HHCS

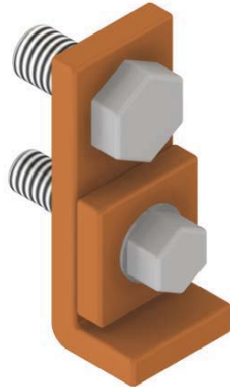

Ordering Codes

Part #	Description
BA-AWS0919	Copper Ground Clamp & Lug for Base Cans

