

L-867 Class 1A Light Base

Compliance and Applications

Certified to FAA AC 150/5345-42 (Current Revision)
L-867 Class 1A; Size: B=12", D=16", E=24"

Our FAA approved, non-load bearing light bases are designed for locations which experience occasional light vehicular loading, but no aircraft or other heavy vehicular load. The base typically supports an elevated taxiway light fixture and houses a power-isolation transformer. It can also be used solely as a junction box or transformer housing.

Specifications

- Steel construction with hot dip galvanized finish
- Galvanized to ASTM-A123/A123M-02
- (6) 3/8-16 equally spaced UNC threaded thru holes
- (6) 3/8-16 x 1" stainless hex head cap screws
- Conduit openings (min. 2) are:
 - Located 180° apart, 2.5" up from bottom
 - Various sizes and locations are available
 - Protective plug installed in threaded hubs
 - Flex Connex Grommets are shipped loose
- Internal/External ground straps are standard
- L-867B (12") bases have a standard Ø3/4" drain hole with a removable plug
- Diameter: B=12" (10.25" BC), D=16" (14.25" BC), E=24" (21.5" BC)
- Height: 24" (available up to 36")
- 1/2" plywood cover

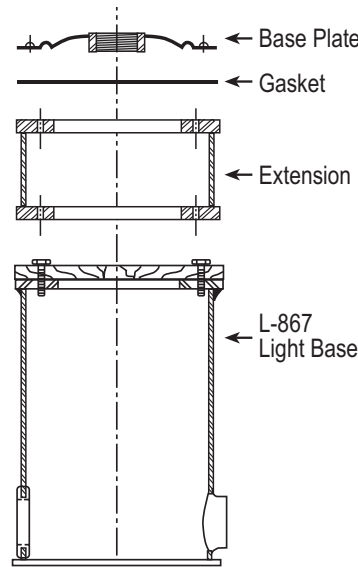
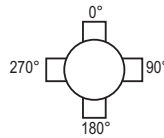

Dimensions

Base Type	TOD/BOD	ID	BC	TID
12" L-867B	13.5" (342.9)	12.25" (311.2)	10.25" (260.4)	9.25" (235)
16" L-867D	17.375" (441.3)	16.25" (412.8)	14.25" (362)	12.375" (314.3)
24" L-867E	24" (609.6)	22.5" (571.5)	21.5" (546.1)	20" (508)

(length in mm)

Ordering Codes

Base Type	Conduit Opening Type	Conduit Locations	Ground Strap*	Drain Hole
BA-L867B: 12" L-867B	G: Grommets for 2" PVC	2: 0°, 180°	0: None	0: None
BA-L867D: 16" L-867D	H: Hubs for 2" PVC	3: 0°, 90°, 180°	I: Internal	D: 3/4" hole
BA-L867E: 24" L-867E	J: Special grommet size K: Special hub size	4: 0°, 90°, 180°, 270° S: Specify	E: External Q: Internal & External	E: 1" hole S: Specify

* Ground required for FAA approval

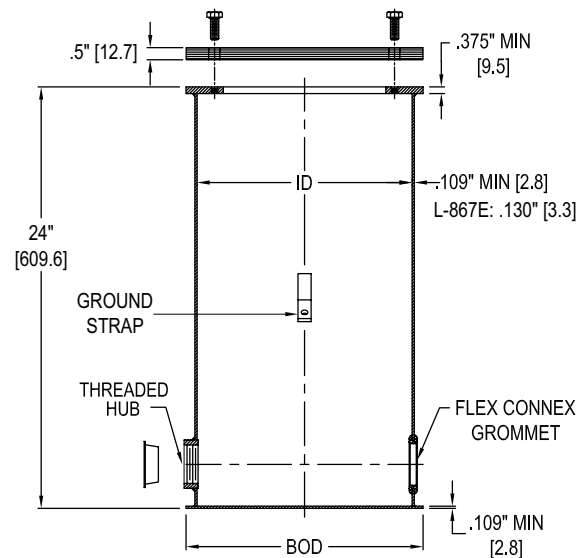
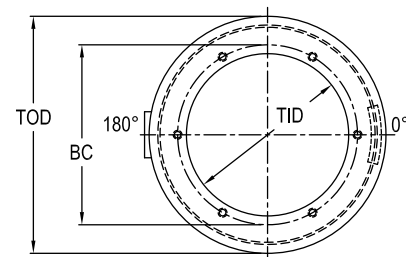

+1.800.806.3548 USA
+1.916.394.2800 Worldwide

www.flightlight.com
sales@flightlight.com

Flight Light Inc., 2708 47th Ave.
Sacramento, CA, 95822, USA



Copper Ground Clamp & Lug for Base Cans

Applications

Copper clamp for attaching copper cable to base can ground strap. Stainless steel hardware.

Specifications

- Material: copper
- Hardware:
 - 5/16" -18 x 1-1/4" SS HHCS
 - 5/16" -18 SS Wiz-Lock Nut
 - 1/4" -20 x 1" SS HHCS

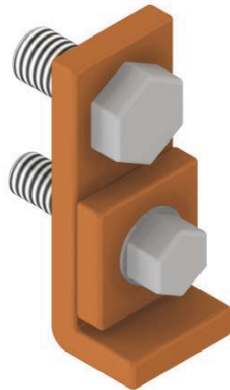

Ordering Codes

Part #	Description
BA-AWS0919	Copper Ground Clamp & Lug for Base Cans

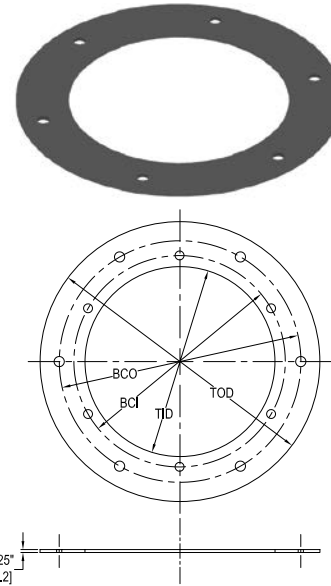
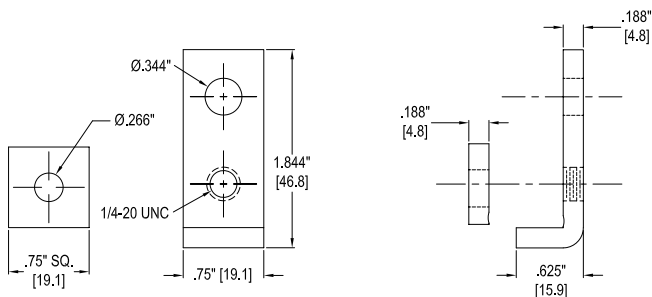

Neoprene Gasket for Base Cans

Applications

Neoprene gasket for sealing light bases.

Specifications

- Certified to FAA AC 150/5345-42 (Current Revision) L-867; Size: B=12", D=16", E=24"
- Material:
 - Neoprene Durometer 55
 - Neoprene R431 (foam) (Alaska application)
- (6) 7/16" Ø equally spaced, thru holes

Ordering Codes

Part #	TOD	BCO	BCI	TID
BA-2052 12" L-867B	11.938" (303.2)	11.25" (285.8)	10.25" (260.4)	9" (228.6)
BA-10532042 12" L-867B*	11.938" (303.2)		10.25" (260.4)	9" (228.6)
BA-10530281 16" L-867D	15.938" (404.8)	14.25" (362)		12.438" (315.9)
BA-10533055 24" L-867E	23.75" (603.3)	21.5" (546.1)		20" (508)

(length in mm)

* Alaska application.