



MWI-05-001 – Rev. H

## Installation and Maintenance Manual



### Steady Burning LED Red Obstruction Light Low Intensity



- Tel: 800.806.3548 (USA) or 1.916.394.2800
- [www.flightlight.com](http://www.flightlight.com)
- [sales@flightlight.com](mailto:sales@flightlight.com)
- 2708 47<sup>th</sup> Avenue, Sacramento, CA 95822-3806



MWI-05-001 – Rev. H



## Table of Contents

1. Introduction .....	1
1.1 About the manual .....	1
2. Safety Measures.....	2
3. Installation .....	3
3.1Wiring Diagram & Instructions .....	4
3.2 Single Head Obstruction Lights .....	6
3.2.1 Single Head Obstruction Light with Photocell .....	6
3.2.2 Mounting Options:.....	7
3.3 Dual Head Obstruction Light.....	8
3.3.1 Dual Head Obstruction Light with Photocell.....	8
3.3.2 Dual Head Obstruction Light with Flasher and Photocell .....	8
3.3.3 Dual Head Obstruction Light with Transfer Relay.....	9
3.3.4 Dual Head Obstruction Light with Transfer Relay and Photocell.....	10
3.3.2 Mounting Options:.....	10
4. Replacement Parts .....	12
5. Maintenance and Repair.....	14
6. Limited Warranty .....	15



MWI-05-001 – Rev. H

## 1. Introduction

Input Voltage: 100-277VAC, 12-48VDC

Power Consumption: 2.4W for DC and 3W for AC

Operating Temperature Range: -55 to +55 Celsius; -67 to +131 Fahrenheit

Humidity: to 95% relative humidity

Wind: Wind speeds up 150 mph

Wind Blown Rain: Exposure to wind-blown rain from any direction

Salt Fog: Exposure to salt-laden atmosphere

The installation and maintenance should be done by authorized personnel only.

For questions or guidance during the installation process, please contact our office. Our engineers and technicians are always available to help you.

Phone number: 1-800-806-3548  
1-916-394-2800

OR send an email request to [sales@flightlight.com](mailto:sales@flightlight.com)

### 1.1 About the manual

This manual contains important information regarding the safety, operation, and maintenance of this product. Before using the product, read and understand all cautions warning, instructions, and product labels. Failure to do so could result in injury and/or void the warranty.



MWI-05-001 – Rev. H

## 2. Safety Measures

You must know whether your lighting system is powered by AC or DC before installing the fixture. AC models work on a range of 100 to 277VAC and DC models operate from 12 to 48VDC. The lights are designed to be installed in a parallel circuit, which maintains a constant voltage and brightness for all lights.

Ensure power is off before installing or servicing lighting fixtures!

Follow the local electrical code!

Make sure the equipment is rated and approved for the environment in which you are intending to use it. Do not operate this equipment in humid, flammable, or explosive environments unless it has been rated for safe operation in these environments.

Use only electrical wire of sufficient gauge and insulation to handle the rated current and voltage demand.

Route electrical wiring along a protected path. Make sure they will not be damaged by moving equipment.

Protect components from harsh environment conditions.

Protect equipment with safety devices as specified by applicable safety regulations.

Before starting this equipment, check all safety interlocks, fire –detection systems, and protective devices such as panels and covers. Make sure all devices are fully functional. Do not operate the system if these devices are not working properly.

Never operate equipment with a known malfunction.

Do not attempt to operate or service electrical equipment if standing water is present.

Do not touch exposed electrical connections on equipment while the power is ON!

Wiring and electrical design should be authorized by an electrical contractor.

To provide maximum protection from surges, ensure that the system ground is tested and provides less than 25 ohms to ground resistance.



MWI-05-001 – Rev. H

### 3. Installation

The installation of a new complete LED light is similar to that of an incandescent light source assembly.

1. Verify that all supply power is off
2. Use the below wiring diagram and ensure your incoming power is matching the voltage the light was built for.
3. Connect the wires from the fixture to the wires from the power source
4. Make sure the connection is done in a protected, waterproof enclosure.
5. The blue wire is defined as the **Alarm Line**, when the red LED fails the input voltage will be present at this wire. For example, a 120VAC input fixture at normal conditions will have 0VAC at the blue wire, in case of LED failure (turning off), it will energize the blue wire to the input voltage, this case 120VAC.

**CAUTION! The Alarm Line (Blue Wire) will be energized to high voltages during a failure of the LED/Lamp.**



MWI-05-001 – Rev. H

### 3.1 Wiring Diagram & Instructions

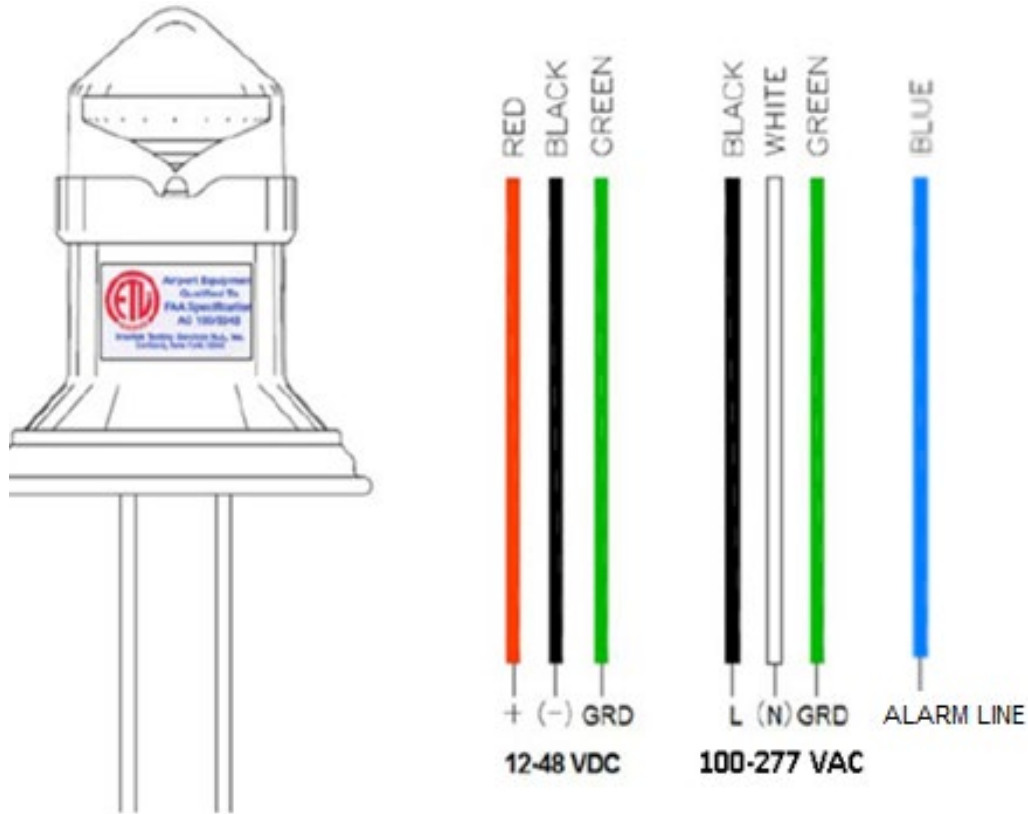

**CAUTION! The Alarm Line (Blue Wire) will be energized to high voltages during a failure of the LED/Lamp.**



MWI-05-001 – Rev. H

The wires **must not** be left exposed. The splice should be done in a secure, waterproof junction box and by using waterproof connectors.

Electrical tape and wire nuts alone don't properly insulate the wires from moisture, a waterproof junction box should always be used. Water and moisture entering through the cables will damage the light. Such damages are not covered under warranty.

The below two pictures are only examples of a correct installation. Junction boxes and connectors are not provided with the lights.







MWI-05-001 – Rev. H

### 3.2 Single Head Obstruction Lights



Height: 9"  
Width: 5.75"  
Weight: 3.30 Lbs

#### 3.2.1 Single Head Obstruction Light with Photocell



Height: 9"  
Width: 10.5"  
Weight: 4.10 Lbs



MWI-05-001 – Rev. H

### 3.2.2 Mounting Options:

#### A. *Low Surface Mount*



1. Mount box to surface
2. Install fittings or conduit using sealing compound on threads.
3. Pull supply wires into box.
4. Thread the light into the cover and run the wires through the top hole and through the gasket. See picture below. Connect/Splice them to the incoming power cables.
5. Attach system ground wire under head of green screw in box.
6. Center cover gasket evenly. Locate pre-perforated holes in the gasket and install the gasket so they align with the mounting holes in the box. Install cover with the two screws provided.
7. Use caulking around cover.
8. Cover the conduits that are not used with the plugs provided.





MWI-05-001 – Rev. H

### 3.3 Dual Head Obstruction Light

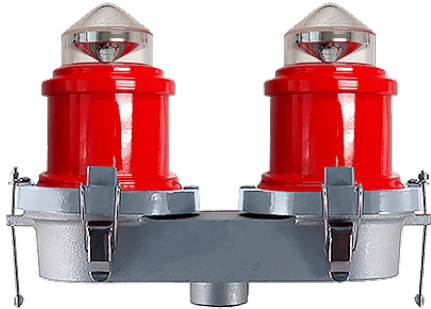

Height: 9"  
Width: 11"  
Weight: 6.55 Lbs

#### 3.3.1 Dual Head Obstruction Light with Photocell



#### 3.3.2 Dual Head Obstruction Light with Flasher and Photocell



Height: 15 1/2"  
Width: 11"  
Weight: 10.20 Lbs



MWI-05-001 – Rev. H

### 3.3.3 Dual Head Obstruction Light with Transfer Relay

#### Transfer Function (L-810LED Double Obstruction Light with Transfer Feature added)

A Transfer Event will occur when the primary light on an L-810LED double fixture fails, this will cause the secondary light to activate/turn on.

Upon replacement of the faulty primary light, it will reset the system to normal operating mode: The primary light on the L-810 dual fixture will be active/turned on and the secondary light will operate as a backup, remain turned off, until a primary light failure occurs causing a Transfer Event.



Height: 14”  
Width: 11”  
Weight: 10.50 Lbs



MWI-05-001 – Rev. H

### 3.3.4 Dual Head Obstruction Light with Transfer Relay and Photocell



Height: 14"  
Width: 11"  
Weight: 11.25 Lbs

### 3.3.2 Mounting Options:

#### A. Floor Flange

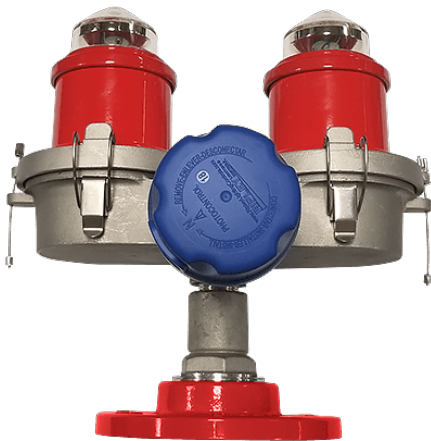

For a quick installation on top of a flat surface, we offer the 6" Diameter Floor Flange with 2" thread.

The connection to the floor flange is done through our FAA 2" Frangible Floor flange.

The bolts for the floor flange are not provided by Flight Light.



MWI-05-001 – Rev. H

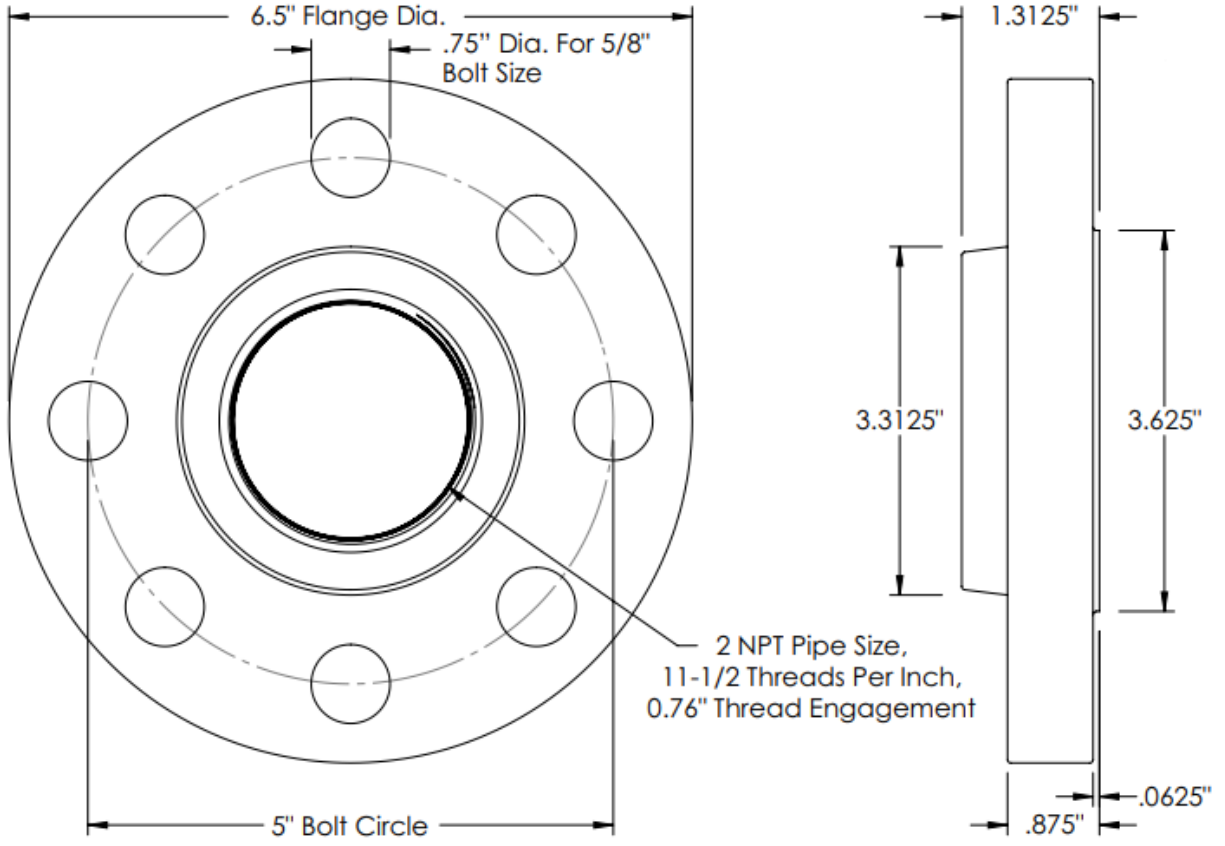



#### 4. Replacement Parts

No.	Part Number	Part Description
1.	FL-810LED-AC	100-277 VAC LED Replacement Light Head
2.	FL-810LED-DC	12-48 VDC LED Replacement Light Head
3.	22-SK4545	Clamp Ring
4.	22-SK4454	Neoprene Gasket
5.	12-SB3/SB4	Single Casting L-810
6.	12-DB3/DB4	Double Casting L-810

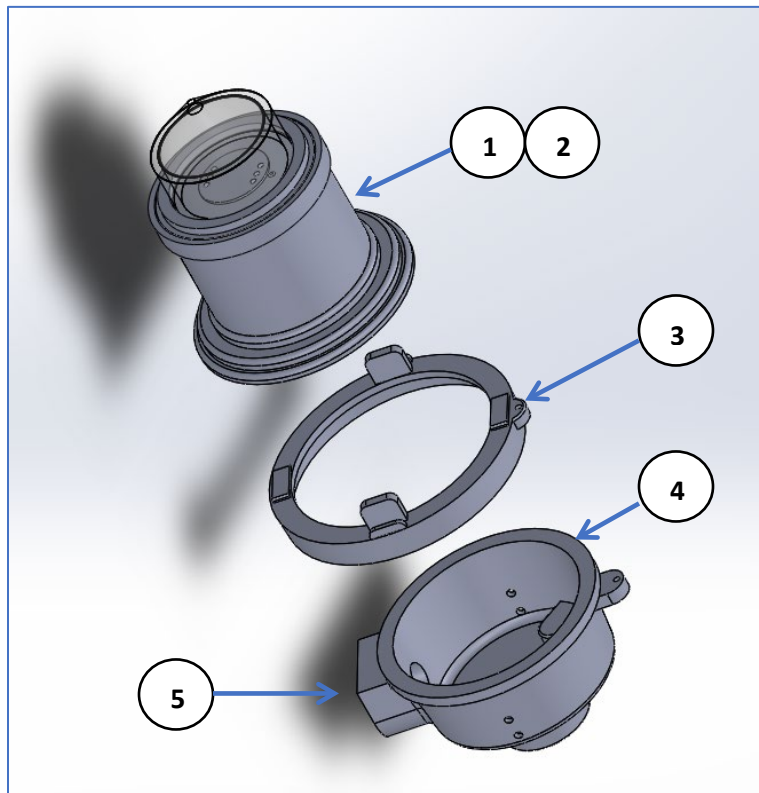



MWI-05-001 – Rev. H

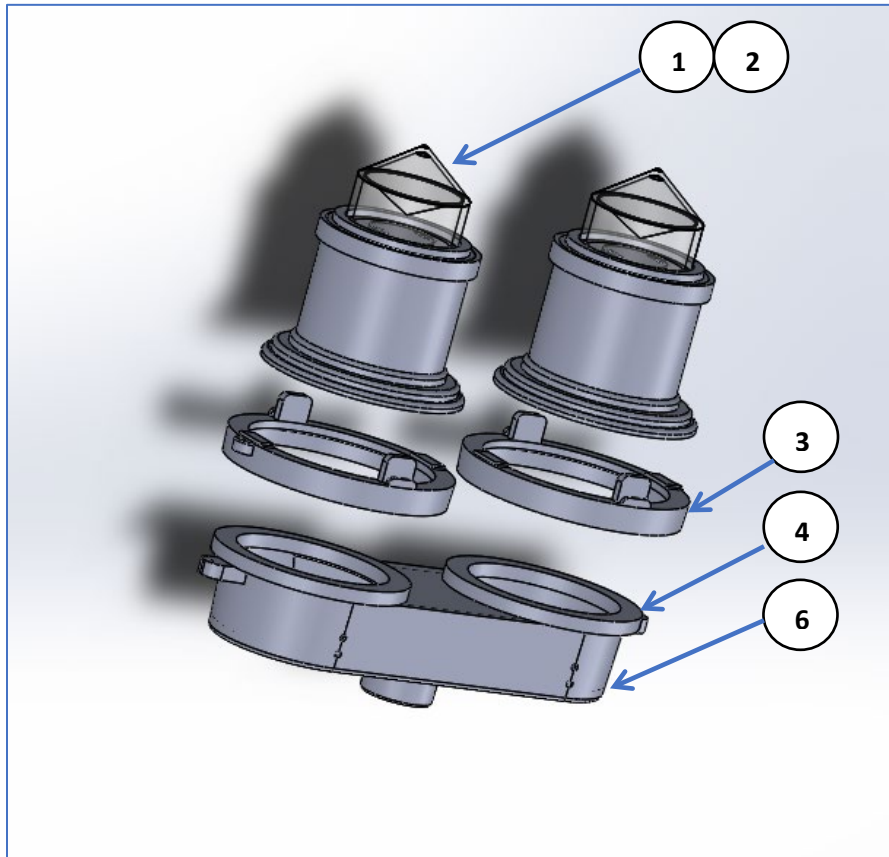





MWI-05-001 – Rev. H

## 6. Maintenance and Repair

No regularly scheduled maintenance is required for the unit.

Life time expectancy is 70,000+ hours.

The LED board is sealed inside the top head assembly. In case of failure the entire engine must be replaced.

1. Ensure power is off before servicing the lighting fixture
2. Open the Clamp Ring that is holding the top assembly and the bottom casting together
3. Remove the existing engine
4. Run the wires from the new engine through the bottom casting and position the unit over the gasket located in the bottom casting
5. Secure the unit by closing the clamp ring

The functionality of the Flight Light Low Intensity Obstruction lights is not affected by their use in conjunction with another LED lights or another manufacture's LED obstruction lights.

The performance and life time expectancy of the Flight Light Low Intensity Obstruction Light(s) may be affected if controlled by another manufacture's controller. In consequence, if the lights are used with another's manufacture controller, the warranty will be voided. We don't recommend using our L810LED obstruction lights with another controller, but our FL-81051 Series.



## 7. Limited Warranty

**Duration of the Warranty:** Flight Light Inc. warrants all of the goods which it has manufactured to be free of material defects for the following durations.

Lamps: For a period of 90 days from the date of shipment to Buyer. Product liability is limited to lamp replacement and does not include incidental labor.

LED Light Fixtures: For a period of 5 years from the date of shipment to Buyer.

**Buyer's Remedies:** If any such goods are found to be materially defective within the warranty period, Flight Light Inc. agrees to attempt to repair, and if unable to repair, to replace the defective goods without charge to Buyer.

Buyer's remedy with respect to such goods is limited to repair or replacement. For goods not manufactured by FLI, Buyer agrees to accept as its sole remedy the warranty, if any, offered by the manufacturer or manufacturers of such goods. FLI makes no warranties, express or implied, other than those stated in this paragraph.

**Warranty Exclusions:** Flight Light Inc. shall not be liable under this warranty if any of the following conditions apply:

- 1) Unauthorized personnel attempt any repairs to Flight Light Inc. products without Flight Light Inc. consent.
- 2) Products are damaged by natural phenomenon, misuse, abuse, accident, alteration, or incorrect electrical current or voltage.
- 3) Products are improperly installed, or damaged in shipping.

### Warranty Limitations

FLI makes no warranties, express or implied, other than those stated herein. FLI does not warranty the workmanship of the installer, damage caused by acts of nature, vandalism, improper installation, or damage caused by improper maintenance. The warranty period of LED fixtures covered under the 5-year system warranty is reduced to two years when fixtures are subjected to abrasive materials or chemicals. FLI reserves the right to either repair or replace any defective component covered under the terms of any of its warranties. FLI is not an engineering firm and makes no expressed or implied warranty as to the applicability of its products or systems in any specific situation, application or location: such decisions are the responsibility of the owner, design engineer and/ or others. Therefore, as to all goods sold by FLI, FLI hereby disclaims any implied warranty of merchantability or implied warranty of fitness for a particular purpose and Buyer agrees that FLI shall not be liable for any special, indirect, incidental, consequential or liquidated damages of any kind, whether the Buyer's or any other claim is based upon contract, tort or any other legal theory.