

L-868 Class 1A Light Base Top Section

Compliance and Applications

Certified to FAA AC 150/5345-42 (Current Revision)
L-868 Class 1A; Size: A=8", B=12", C=15"

L-868 light base top section. Facilitates overlay paving.

Specifications

- Steel construction with hot dip galvanized finish
- Galvanized to ASTM-A123/A123M-02
- Diameter: A=8" (7.25" BC), B=12" (11.25" BC), C=15" (14.25" BC)
- Height must be specified at time of order, 2.25" minimum
- (12) 3/8"-16 equally spaced, tapped holes are aligned with bottom holes
- (6) 7/16" Ø equally spaced, thru holes
- Top Sections are shipped with:
 - (6) 3/8"-16 x 1" stainless hex head screws
 - (6) 3/8", 2 piece locking washers
- Size A, 8" top section top holes are located at 30°, 60°, 120°, 150°, 210°, 240°, 300°, 330°

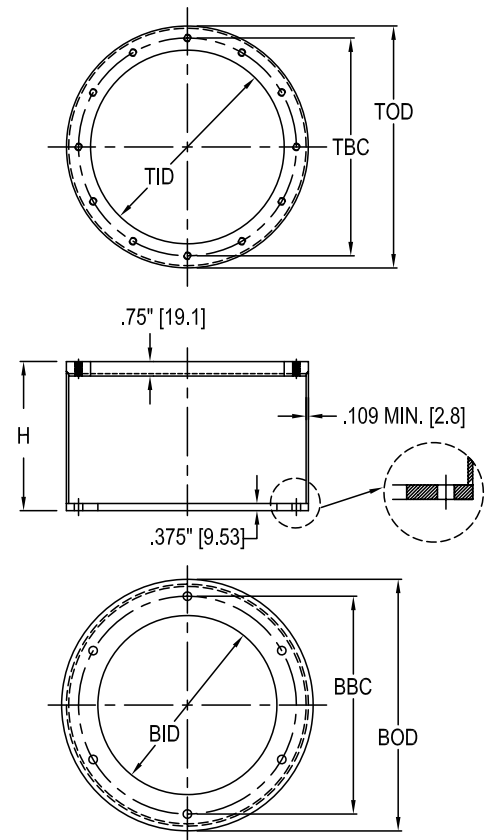
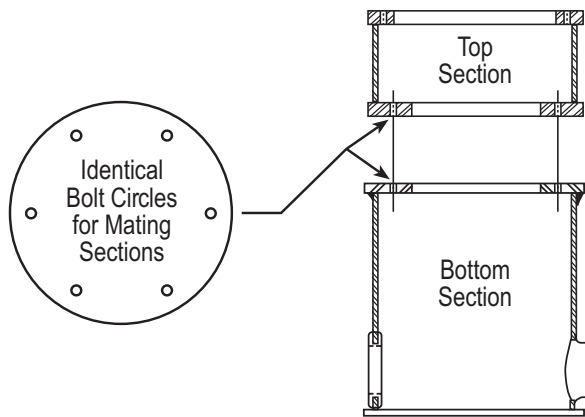

Ordering Codes

Part #	TOD & BOD	TBC	BBC	TID	BID
BA-0829F-XX* 8" L-868A	8.5" (215.9)	7.25" (184.2)	6.25" (159.6)	6.5" (165.1)	5.25" (134.1)
BA-2419F-XX* 12" L-868B	12.5" (317.5)	11.25" (285.8)	10.25" (260.4)	10" (254)	9.25" (235)
BA-3519F-XX* 15" L-868C	15.5" (393.7)	14.25" (362)	13.25" (336.6)	13" (330.2)	12.375" (314.3)

(length in mm)

* Specify height in inches, 2.25" minimum (e.g., 5" = "-05")

+1.800.806.3548 USA
+1.916.394.2800 Worldwide

www.flightlight.com
sales@flightlight.com

Flight Light Inc., 2708 47th Ave.
Sacramento, CA, 95822, USA