



Flight Light Inc.
2708 47th Ave.
Sacramento, California, U.S.A.
95822-3806



PH (916) 394-2800 FX (916) 394-2809
TF (800) 806-3548 EM info@flightlight.com

Low Intensity Elevated Lights "LIEL"
120 and 240 Volts
FAA Compliant L-860

Low Intensity Elevated Lights

Low intensity constant voltage elevated runway and taxiway edge lights ("LIEL") mark the outlines of heli-pads, runways and taxiways and runway threshold and end. The fixture consists of a clear or colored Fresnel lens (globe) mounted on an aviation yellow powder coated cast aluminum lamp housing. The powdercoat finish complies with the US Military Standard Salt Fog Test conducted per MIL-STD-810E, Method 509.3, Procedure 1 for corrosion resistance. The lamp is secured by an O-ring seal and clamp band. The upper assembly mounts on a 1" EMT extension into the 1.5" NF aluminum breakable coupling. An optional 2" NPS breakable coupling is available. All of the hardware is stainless steel.

The LIEL may be mounted on a base plate or stake, sold separately. The light is furnished with wire leads for wiring in the field. Most of the replacement parts are compatible with other manufacturers; consult Flight Light with specific inquiries. With a low initial cost and up to 8,000 hours rated lamp life (69W), the LIEL is the most economical light we offer.



Flight Light LIEL
(Shown on base plate, sold separately.)

Base Mounted
12" Base Plate
(sold separately)

Shallow Base Mounted
5" Shallow Base and
8.5" Base Plate
(sold separately)

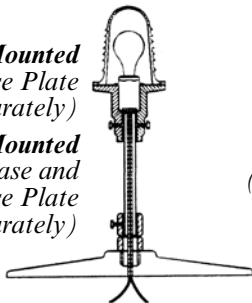

Stake Mounted
30" Angle-Iron
Mounting Stake
(sold separately)



Ordering Codes

Fixture	Globe Color	Lamp & Power	Mounting Height	Fixture Options
FL-860	B: Blue	60A2: 60W, A21, 230V 69A: 69W, A21, 120V	14: 14" (standard)	1: 1.5" Frangible Coupling (FL-FC1.5)
	C: Clear		24: 24" (extended)	
	G: Green	30: 30" (extended)	2: 2" Frangible Coupling (FL-FC2.0)	
	R: Red			
	X: Blank			
	Y: Yellow			
	GR: Green/Red			
CY: Clear/Yellow				

FL-860				
--------	--	--	--	--

Shipping Weight: 3.2 lb./1.5 kilo., Volume: 0.5 cu. feet/0.01 cu. meters

Visit our web site: www.flightlight.com



Flight Light Inc.
 2708 47th Ave.
 Sacramento, California, U.S.A.
 95822-3806



Low Intensity Elevated Lights "LIEL"
120 and 240 Volts
FAA Compliant L-860

PH (916) 394-2800 FX (916) 394-2809
 TF (800) 806-3548 EM info@flightlight.com

Common Replacement Parts

61-861B	L861-Glass Blue
61-861C	L861-Glass Clear
61-861Y	L861-Glass Yellow
N/A	Lexan Globes Available (call for details)
61-80001*	L861-Clamp Band (stainless steel)
61-80002	L861-O-Ring Gasket

FL-FC1.5	L861-1.5" Frangible Coupling (metal)
FL-FC2.0	L861-2" Frangible Coupling (metal)
61-80004	Medium Base Socket
LA-15386IP	Lamp: 60 Watt, A21, 230V (1,000 rated life)
LA-12496-1	Lamp: 69 Watt, A21, 120V (8,000 rated life)
LA-12833	Lamp: 116 Watt, A21, 120V (8,000 rated life)

* Clamp band only compatible with Flight Light fixtures.

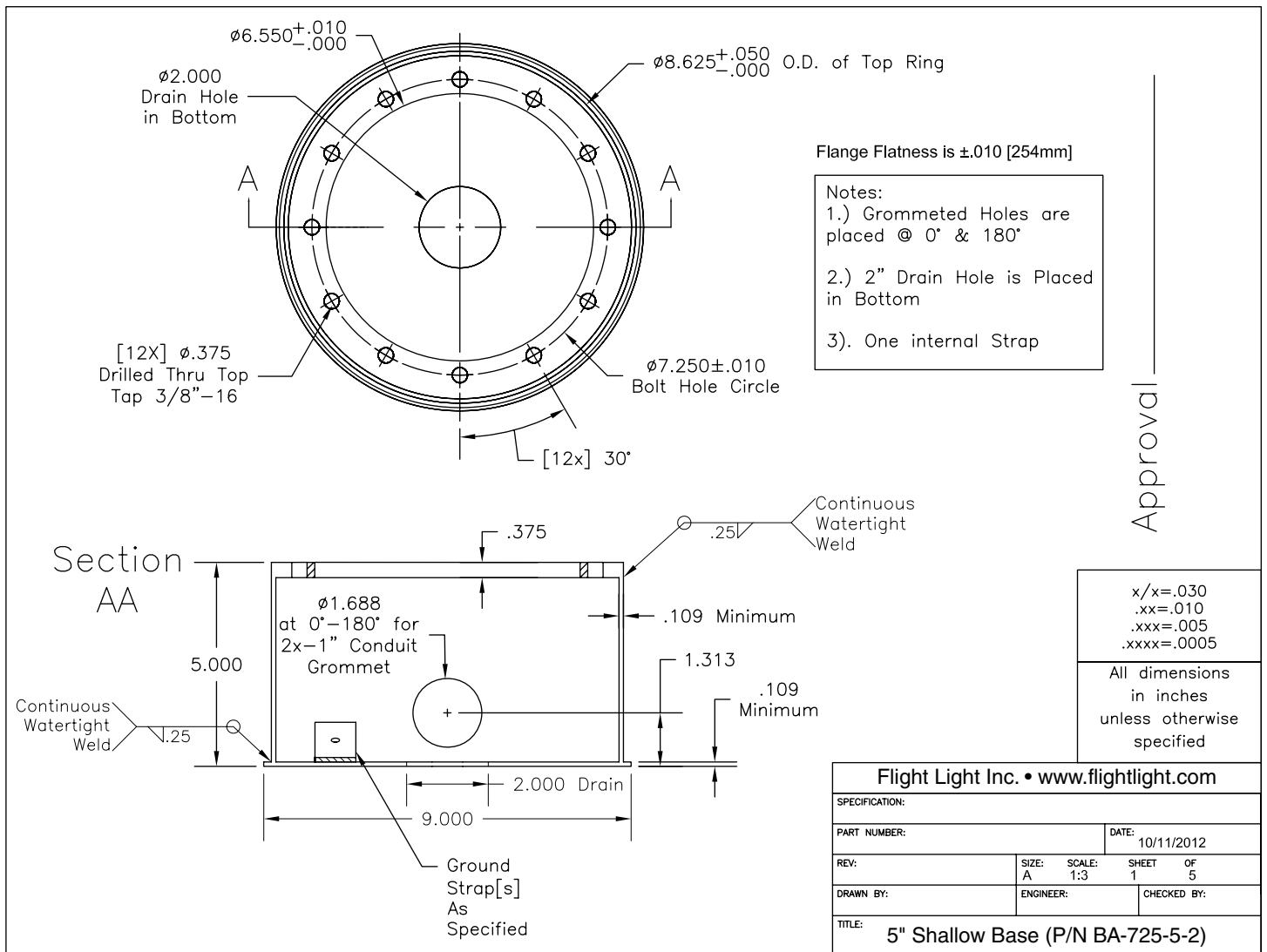

Approval

Visit our web site: www.flightlight.com



Flight Light Inc.
2708 47th Ave.
Sacramento, California, U.S.A.
95822-3806



PH (916) 394-2800 FX (916) 394-2809
TF (800) 806-3548 EM info@flightlight.com

Low Intensity Elevated Lights "LIEL"
120 and 240 Volts
FAA Compliant L-860

Base Plate for L868AA 5" Shallow Base BA-1935AA-25

Specifications

- Dimensions: 8.5" diameter x .25" thick
- Bolt Circle: 7.25"
- Material: Hot rolled steel
- Finish: Aviation yellow powder coat
- Includes (6) 3/8-16 x 1" stainless steel hex head cap screws
- Part #: BA-1935AA-25

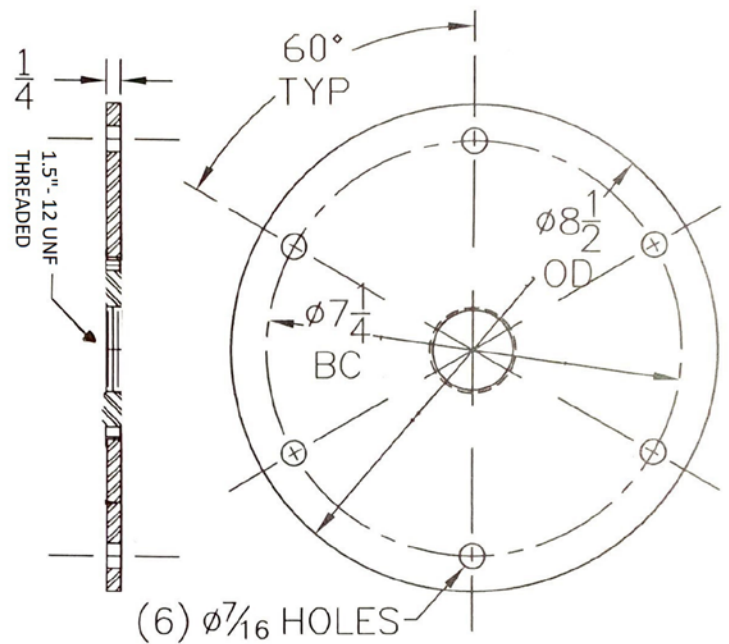

Visit our web site: www.flightlight.com