



Flight Light Inc.
2708 47th Ave.
Sacramento, California, U.S.A.
95822-3806

PH (916) 394-2800 FX (916) 394-2809
TF (800) 806-3548 EM info@flightlight.com

atg airports
(formerly ALSTOM)
ZA420 High Intensity
Elevated Approach Light
FAA Compliant: E-982*,
NATO Stanag 3316, ICAO Annex 14

Compliance and Applications

FAA Compliant: E-982*

NATO Stanag 3316

ICAO Annex 14

Category I, II and III all weather operation airfield lighting systems.

Suitable for use as high intensity, unidirectional, elevated runway approach, siderow barrette, threshold, threshold wingbar and runway end.

Why Our ZA420 is Better

- ✓ Lightweight and robust aluminum alloy construction.
- ✓ No external color filters required.
- ✓ Pre-focused optics to simplify maintenance.
- ✓ Lamp replacement requires no tools.
- ✓ Mounts on existing or new elevated approach towers and 2" EMT posts when ordered with optional pole coupling.
- ✓ 300mm lead included, longer leads available at an extra charge.
- ✓ Installation and maintenance manual AVD 109.

Specifications

- Long life halogen lamps: 1200 hours at full intensity.
- 6.6a from 100w, 150w or 200w.
- Powder coated finish in golden yellow. Stainless steel fasteners.
- Available lamps:
LA-J1/80=100W
LA-J1/83=150W
LA-J1/84=200W
- Net weight 4 lb (1.8kg). Gross weight 5.3 lb (2.4kg). Carton size 8.9 in. x 8.9 in. x 10.2 in. (225mm x 225mm x 260mm)



APPLICATION VARIATIONS

| FAA# | Application | Typical Lamp** | Lens Color | Fixture |
|--------|---|----------------|------------|-----------|
| E-982* | Elevated Approach | 150W | White | 80-ZA420 |
| E-982* | Elevated Approach Siderow Barrette and Runway End | 200W | Red | 80-ZA421 |
| E-982* | Elevated Threshold | 150W | Green | 80-ZA426T |
| E-982* | Threshold Wingbar | 200W | Green | 80-ZA426W |

* Functionally compliant, aiming device sold separately.

** Lamp sold separately.

Visit our web site: www.flightlight.com



Flight Light Inc.
2708 47th Ave.
Sacramento, California, U.S.A.
95822-3806

PH (916) 394-2800
TF (800) 806-3548

FX (916) 394-2809
EM info@flightlight.com

atg airports
(formerly ALSTOM)
**ZA420 High Intensity
Elevated Approach Light**
FAA Compliant: E-982*,
NATO Stanag 3316, ICAO Annex 14

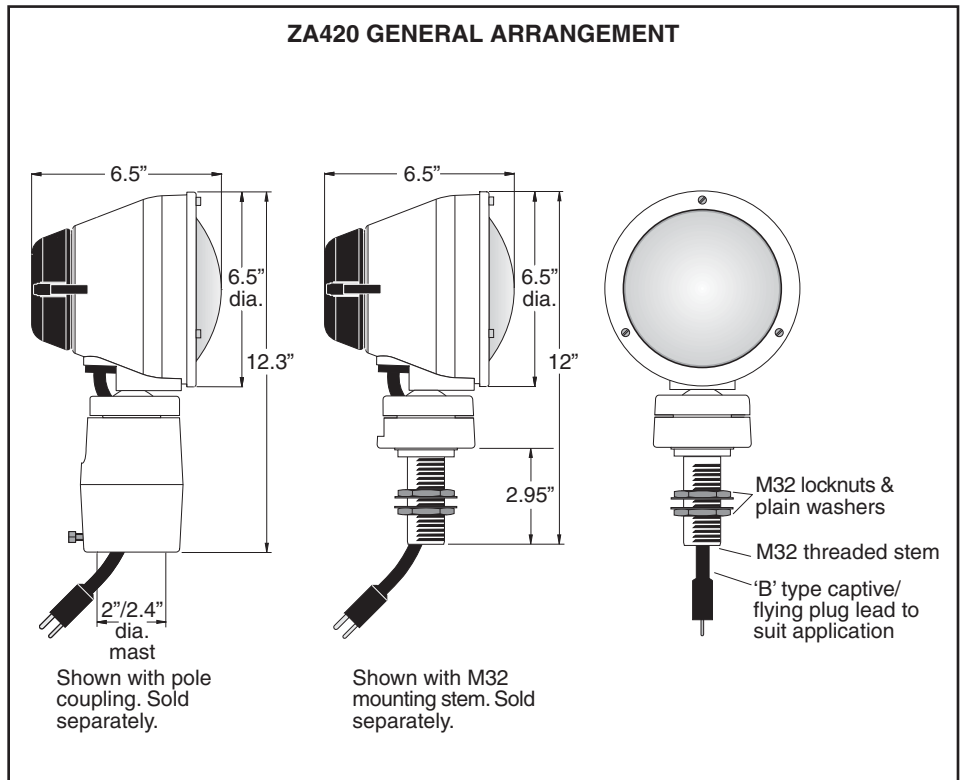
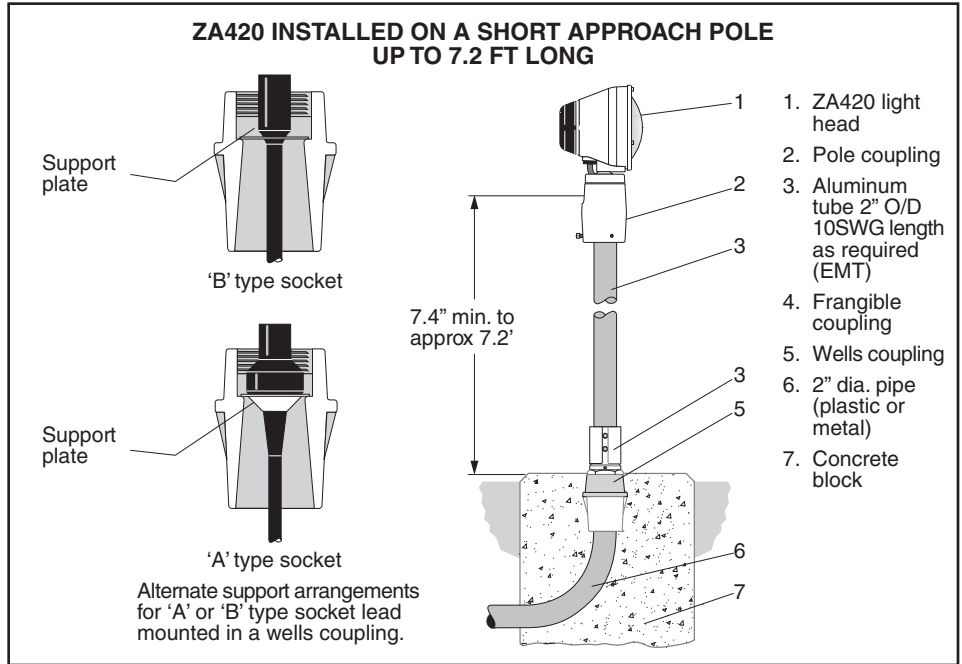
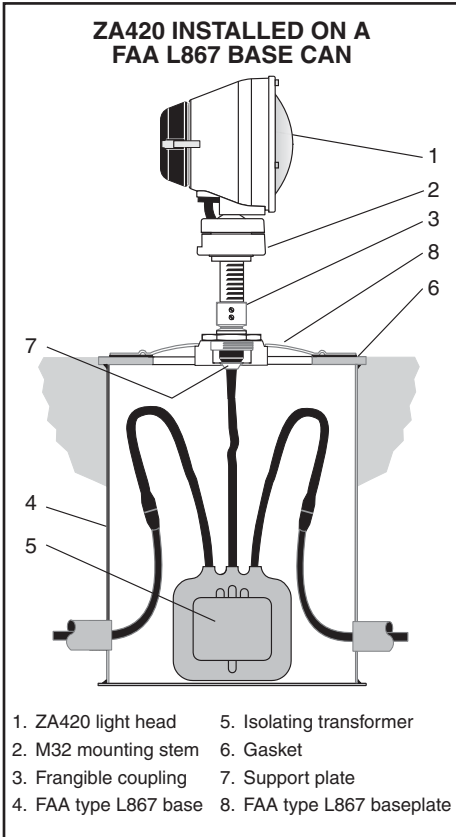

**Do you have any
questions?
Please call
1-800-806-3548**

Visit our web site: www.flightlight.com